



NordicTrack[®]

COMMERCIAL X32i

Model No. NTL39221-INT.0

Serial No. _____

Write the serial number in the space above for reference.

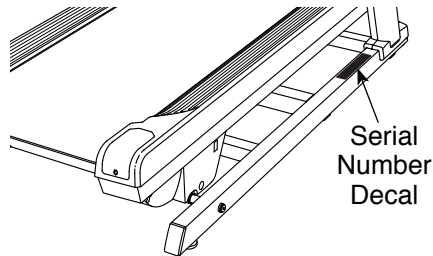

USER'S MANUAL

CUSTOMER SERVICE

UNITED KINGDOM

Call: 0330 123 1045

From Ireland: 053 92 36102

Website: iconsupport.eu

E-mail: csuk@iconeurope.com

Write:

ICON Health & Fitness, Ltd.

Unit 4, Westgate Court

Silkwood Park

OSSETT

WF5 9TT

UNITED KINGDOM

AUSTRALIA

Call: 1800 993 770

E-mail: australiacc@iconfitness.com

Write:

ICON Health & Fitness, Inc.

PO Box 635

WINSTON HILLS NSW 2153

AUSTRALIA



⚠ CAUTION

Read all precautions and instructions in this manual before using this equipment. Save this manual for future reference.

TABLE OF CONTENTS

WARNING DECAL PLACEMENT	2
IMPORTANT PRECAUTIONS	3
BEFORE YOU BEGIN	5
PART IDENTIFICATION CHART	6
ASSEMBLY	7
HOW TO USE THE INCLINE TRAINER	13
HOW TO MOVE THE INCLINE TRAINER	25
MAINTENANCE AND TROUBLESHOOTING	26
EXERCISE GUIDELINES	30
PART LIST	33
EXPLODED DRAWING	35
ORDERING REPLACEMENT PARTS	Back Cover
RECYCLING INFORMATION	Back Cover

WARNING DECAL PLACEMENT

This drawing shows the locations of the warning decals. **If a decal is missing or illegible, call the telephone number on the front cover of this manual and request a free replacement decal. Apply the decal in the location shown.** Note: The decals may not be shown at actual size.

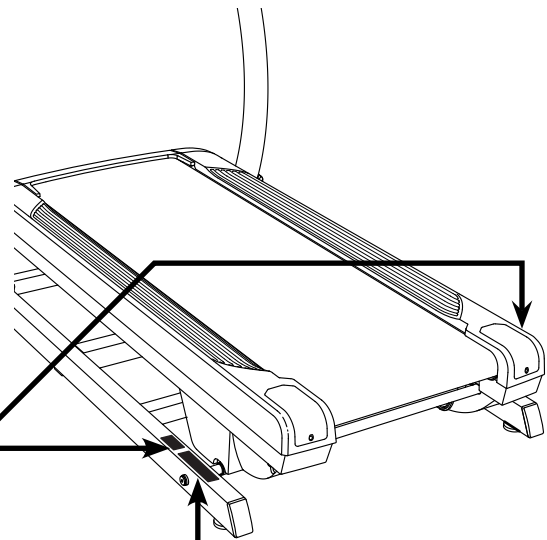

WARNING: Protect yourself and others from risk of serious injury. Read the user's manual or obtain proper instruction before use and:

- Stand only on side rails when starting or stopping treadmill.
- Change speed in small increments.
- Hold handrails to prevent falling, and always wear the safety clip while operating treadmill.
- Stop if you feel faint, dizzy, or short of breath.
- Never allow children on or around treadmill.
- Remove key when not in use.
- Keep clothing, fingers, and hair away from moving belt.
- Never try to adjust or fix the belt while it is moving.
- Always wear athletic shoes while operating treadmill.

NORDICTRACK and IFIT are registered trademarks of ICON Health & Fitness, Inc. Google Maps is a trademark of Google LLC. The Bluetooth® word mark and logos are registered trademarks of Bluetooth SIG, Inc. and are used under license. Wi-Fi is a registered trademark of Wi-Fi Alliance. WPA and WPA2 are trademarks of Wi-Fi Alliance.

IMPORTANT PRECAUTIONS

⚠️ WARNING: To reduce the risk of burns, fire, electric shock, or injury to persons, read all important precautions and instructions in this manual and all warnings on your incline trainer before using your incline trainer. ICON assumes no responsibility for personal injury or property damage sustained by or through the use of this product.

1. It is the responsibility of the owner to ensure that all users of this incline trainer are adequately informed of all warnings and precautions.
2. Before beginning any exercise program, consult your physician. This is especially important for persons over age 35 or persons with pre-existing health problems.
3. The incline trainer is not intended for use by persons with reduced physical, sensory, or mental capabilities or lack of experience and knowledge, unless they have been given supervision or instruction concerning use of the incline trainer by someone responsible for their safety.
4. Use the incline trainer only as described in this manual.
5. The incline trainer is intended for home use only. Do not use the incline trainer in any commercial, rental, or institutional setting.
6. Keep the incline trainer indoors, away from moisture and dust. Do not put the incline trainer in a garage or covered patio, or near water.
7. Place the incline trainer on a level surface, with at least 8 ft. (2.4 m) of clearance behind it and 2 ft. (0.6 m) on each side. Do not place the incline trainer on any surface that blocks air openings. To protect the floor or carpet from damage, place a mat under the incline trainer.
8. Do not operate the incline trainer where aerosol products are used or where oxygen is being administered.
9. Keep children under age 16 and pets away from the incline trainer at all times.
10. The incline trainer should be used only by persons weighing 300 lbs. (136 kg) or less.
11. Never allow more than one person on the incline trainer at a time.
12. Wear appropriate exercise clothes while using the incline trainer. Do not wear loose clothes that could become caught in the incline trainer. Athletic support clothes are recommended for both men and women. *Always wear athletic shoes. Never use the incline trainer with bare feet, wearing only stockings, or in sandals.*
13. When connecting the power cord (see page 13), plug the power cord into an earthed circuit. No other appliance should be on the same circuit. When replacing the fuse in the power cord adapter, insert an ASTA-approved BS1362, 13-amp fuse into the fuse carrier.
14. If an extension cord is needed, use only a 3-conductor, 14-gauge (2 mm²) cord that is no longer than 5 ft. (1.5 m).
15. Keep the power cord away from heated surfaces.
16. Do not operate the incline trainer if the power cord or plug is damaged, or if the incline trainer is not working properly. (See MAINTENANCE AND TROUBLESHOOTING on page 26 if the incline trainer is not working properly.)
17. Read, understand, and test the emergency stop procedure before using the incline trainer. (See HOW TO TURN ON THE POWER on page 15.) Always wear the clip while using the incline trainer.
18. Always stand on the foot rails when starting or stopping the walking belt. Always hold the handrails while using the incline trainer.
19. When a person is walking on the incline trainer, the noise level of the incline trainer will increase.

20. Keep fingers, hair, and clothing away from the moving walking belt.
21. The incline trainer is capable of high speeds. Adjust the speed in small increments to avoid sudden jumps in speed.
22. Never leave the incline trainer unattended while it is running. Always remove the key, press the power switch into the off position (see the drawing on page 5 for the location of the power switch), and unplug the power cord when the incline trainer is not in use.
23. Do not attempt to move the incline trainer until it is properly assembled. (See ASSEMBLY on page 7, and HOW TO MOVE THE INCLINE TRAINER on page 25.) You must be able to safely lift 45 lbs. (20 kg) to raise, lower, or move the incline trainer.
24. Never insert any object into any opening on the incline trainer.
25. Inspect and properly tighten all parts each time the incline trainer is used.
26. **DANGER:** Always unplug the power cord immediately after use, before cleaning the incline trainer, and before performing the maintenance and adjustment procedures described in this manual. Never remove the motor hood unless instructed to do so by an authorized service representative. Servicing other than the procedures in this manual should be performed by an authorized service representative only.
27. Over exercising may result in serious injury or death. If you feel faint, if you become short of breath, or if you experience pain while exercising, stop immediately and cool down.

SAVE THESE INSTRUCTIONS

BEFORE YOU BEGIN

Thank you for selecting the revolutionary NORDICTRACK® COMMERCIAL X32I incline trainer. The COMMERCIAL X32I incline trainer offers a selection of features designed to make your workouts at home more effective and enjoyable.

For your benefit, read this manual carefully before using the incline trainer. If you have questions after

reading this manual, please see the front cover of this manual. To help us assist you, note the product model number and serial number before contacting us. The model number and the location of the serial number decal are shown on the front cover of this manual.

Before reading further, please familiarize yourself with the parts that are labeled in the drawing below.

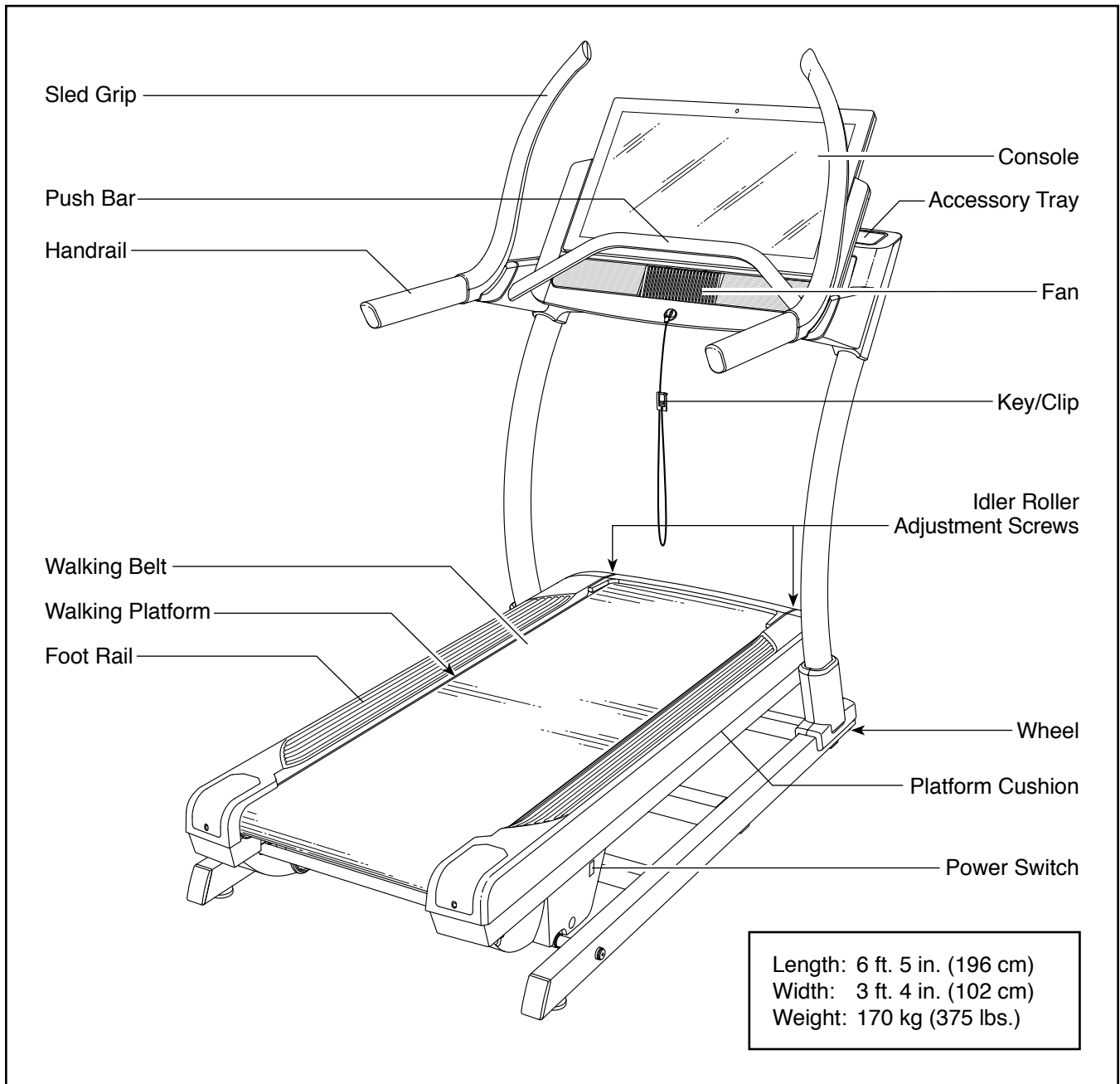

PART IDENTIFICATION CHART

Use the drawings below to identify small parts used for assembly. The number in parentheses below each drawing is the key number of the part, from the PART LIST near the end of this manual. The number following the key number is the quantity used for assembly. **Note: If a part is not in the hardware kit, check to see whether it is preattached. Extra parts may be included.**

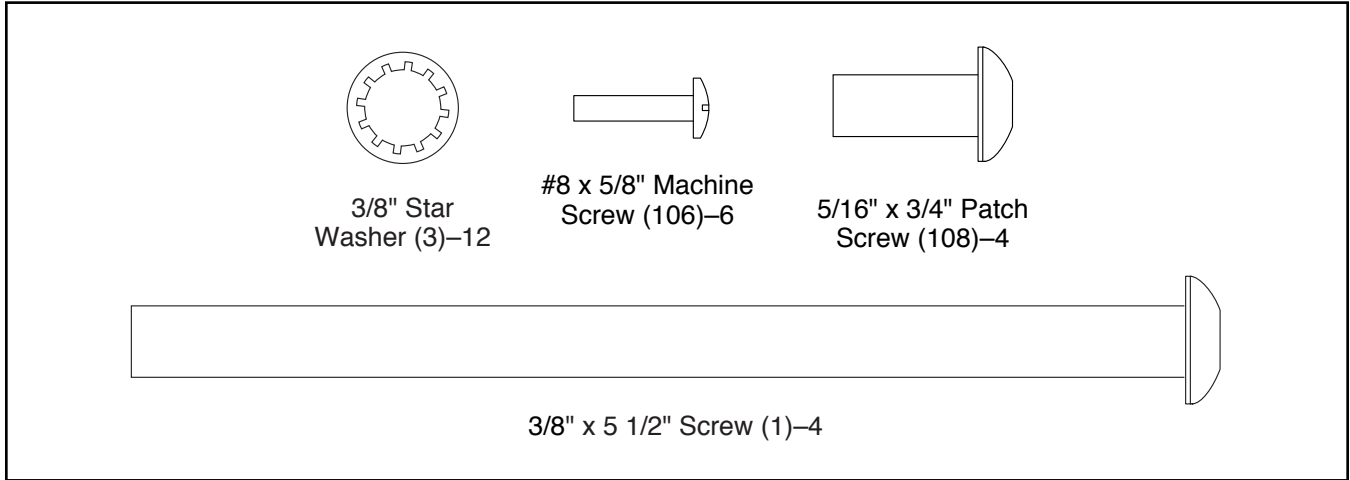

ASSEMBLY

- Assembly requires two persons.
- Place all parts in a cleared area and remove the packing materials. **Do not remove the protective plastic sheet on the console until assembly is completed.** Do not dispose of the packing materials until you finish all assembly steps.
- After shipping, there may be an oily substance on the exterior of the incline trainer. This is normal. If there is an oily substance on the incline trainer, wipe it off with a soft cloth and a mild, non-abrasive cleaner.

- To identify small parts, see page 6.
- Assembly requires the following tools:

the included hex keys 

the included offset screwdriver 

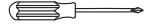
one Phillips screwdriver 

To avoid damaging parts, do not use power tools.

1. **To register your product and activate your warranty in the UK**, go to iconsupport.eu. If you do not have internet access, call Customer Service (see the front cover of this manual).

To register your product and activate your warranty in Australia, email or post the following information to the email address or postal address on the front cover of this manual.

- your receipt (make sure to keep a copy)
- your name, address, and telephone number
- the model number, serial number, and name of your product (see the front cover of this manual)

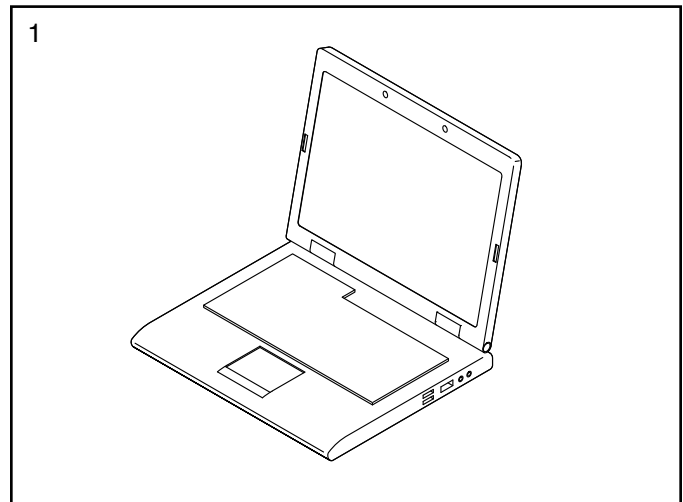

2. **Make sure that the power cord is unplugged.**

Remove the four 3/8" x 3 1/4" Screws (18) from the Base (74) (only one side is shown). **Save the Screws.**

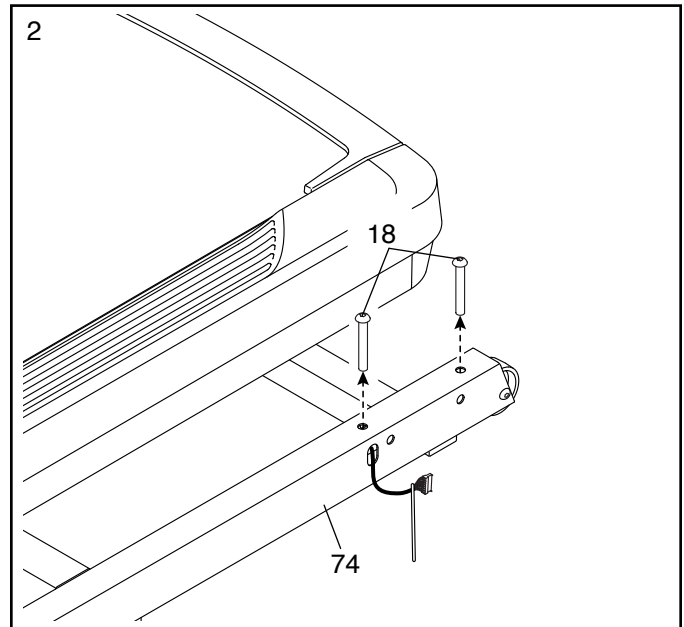

3. Remove the four 3/8" x 2 3/4" Screws (22) from the Uprights (83). **Save the Screws.**

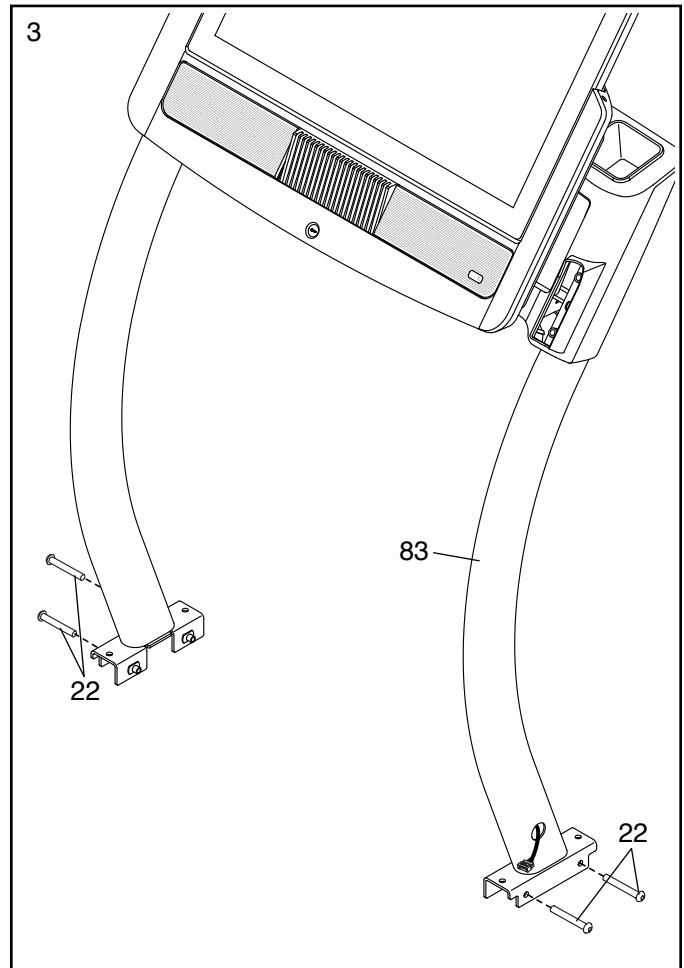

4. Set the Uprights (83) on the Base (74). **Make sure that the hole with the Upright Wire (75) is on the right side.**

Attach the right Upright (83) with two of the 3/8" x 3 1/4" Screws (18) and two of the 3/8" x 2 3/4" Screws (22) that you just removed and four 3/8" Star Washers (3); **do not fully tighten the Screws yet. Make sure that the Base Wire (52) is not pinched.**

Attach the left Upright (not shown) as described above. Note: There are no wires on the left side.

Then, fully tighten the 3/8" x 3 1/4" Screws (18) and the 3/8" x 2 3/4" Screws (22).

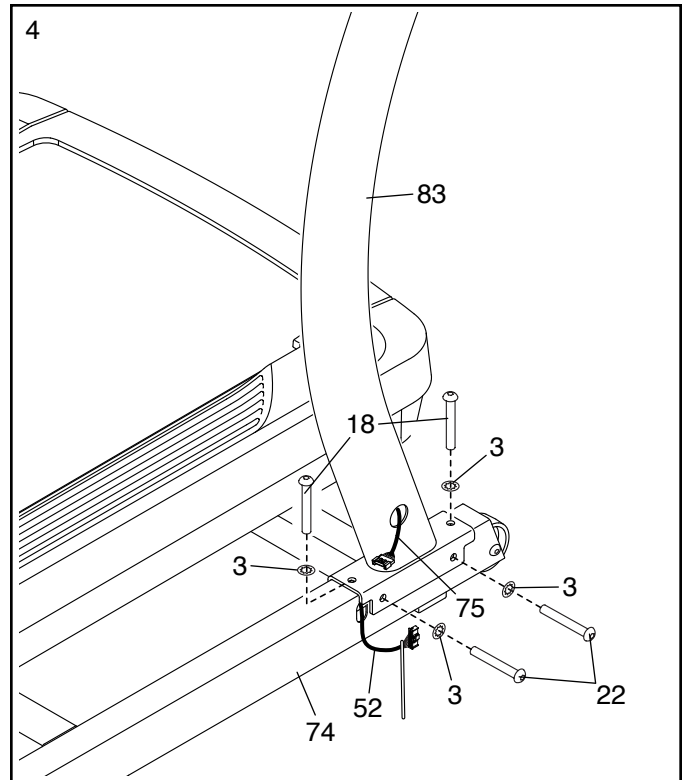

5. Connect the Base Wire (52) to the Upright Wire (75). **The connectors should slide together easily and snap into place with an audible click. If they do not, turn one connector and try again.**

Then, remove the tie (A) from the Base Wire (52), and insert the connectors into the hole (B) in the right Upright (83).

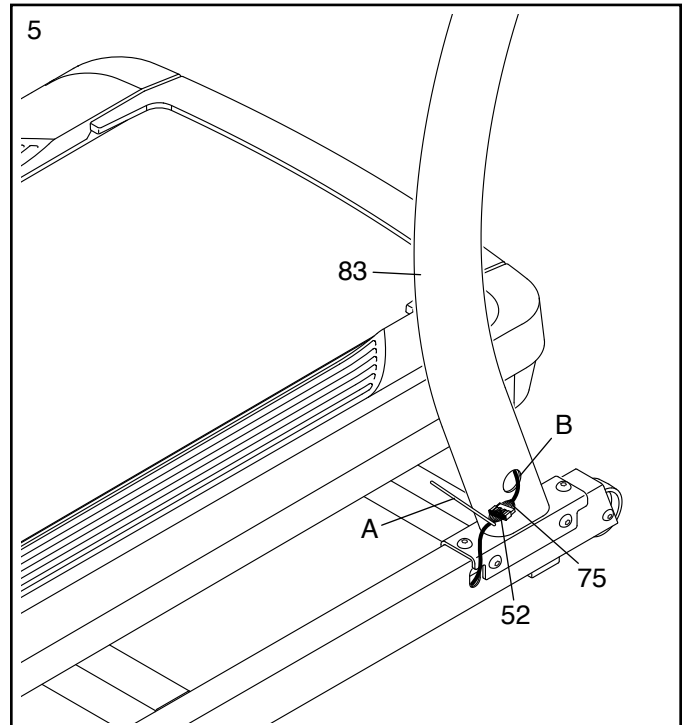

- 6 Set the left handrail assembly (C) on the floor in the position shown.

Attach the Push Bar Bottom (109) to the left handrail assembly (C) with two 5/16" x 3/4" Patch Screws (108); **do not fully tighten the Patch Screws yet.**

Attach the Push Bar Bottom (109) to the right handrail assembly (D) in the same way.

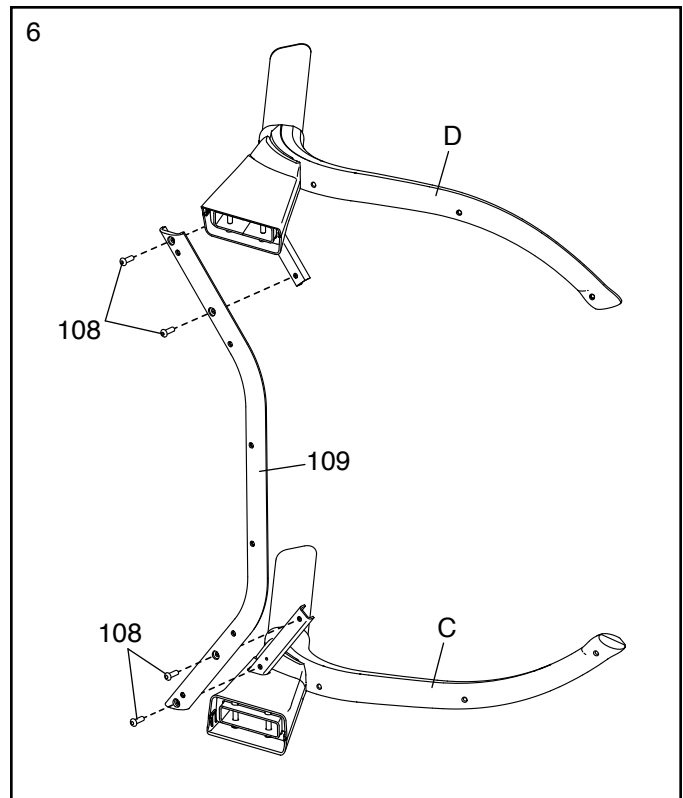

7. Set the handrail assembly (E) on the floor in the position shown. Attach the Push Bar Top (110) to the Push Bar Bottom (109) with six #8 x 5/8" Machine Screws (106); **start all six Machine Screws, and then tighten them. Do not over-tighten the Machine Screws.**

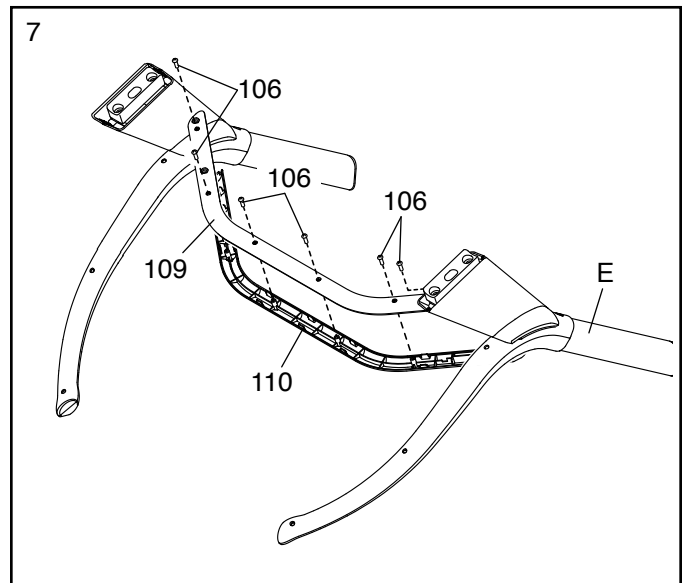

8. **With the help of a second person**, position the handrail assembly (E) below the Console (93) as shown. Then, move both sides of the handrail assembly upward at the same time, sliding the inner corner (F) of the handrail assembly between the Console (93) and the Console Base (92).

Next, attach the handrail assembly (E) with four 3/8" x 5 1/2" Screws (1) and four 3/8" Star Washers (3) (only one side is shown); **start all four Screws, and then tighten them.**

Then, tighten the four 5/16" x 3/4" Patch Screws (108) (only one side is shown).

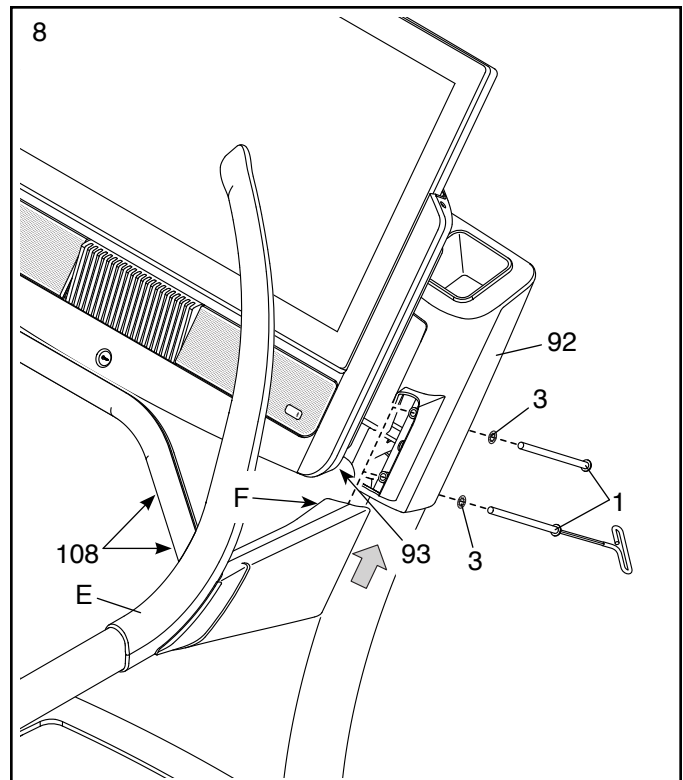

9. Slide the Right Inside Upright Cover (70) against the lower end of the right Upright (83). Then, press the Right Outside Upright Cover (71) against the Right Inside Upright Cover until it snaps into place. **Make sure that the wires (G) are not pinched.**

Attach the Left Inside Upright Cover (not shown) and the Left Outside Upright Cover (not shown) as described above. Note: There are no wires on the left side.

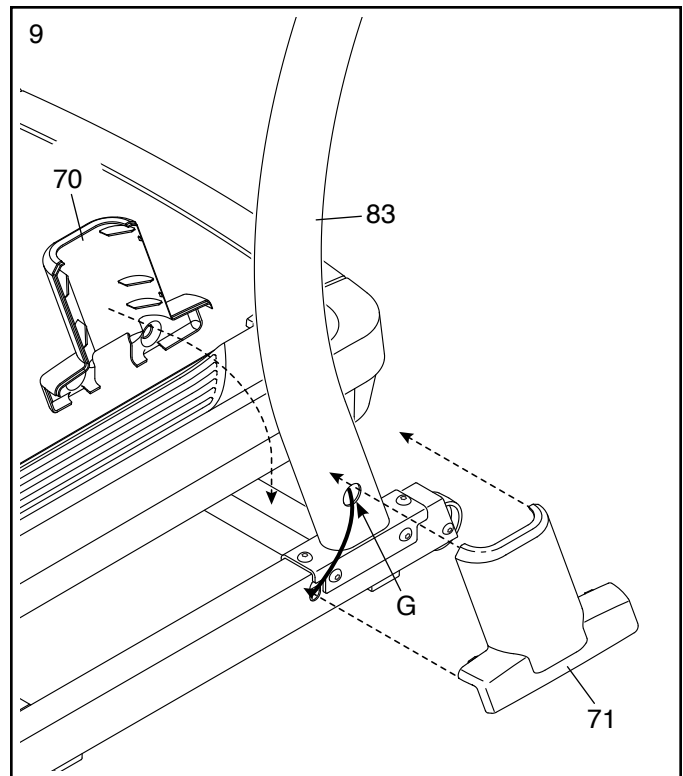

10. If necessary, move the incline trainer to the desired location (see HOW TO MOVE THE INCLINE TRAINER on page 25).

After the incline trainer is placed in the location where it will be used, make sure that the incline trainer rests firmly on the floor. If the incline trainer rocks even slightly, turn a Leveling Foot (77) as needed until the rocking motion is eliminated.

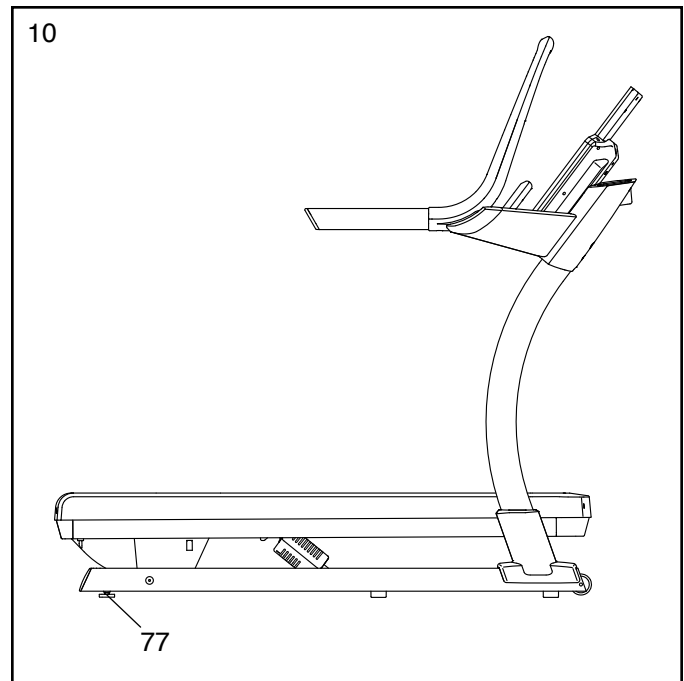

11. **Make sure that all parts are properly tightened before you use the incline trainer.** Keep the included hex keys in a secure place. One of the hex keys is used to adjust the walking belt (see pages 28 and 29). To protect the floor or carpet from damage, place a mat under the incline trainer. To avoid damage to the console, keep the incline trainer out of direct sunlight.

HOW TO USE THE INCLINE TRAINER

HOW TO PLUG IN THE POWER CORD

This product must be earthed. If it should malfunction or break down, earthing provides a path of least resistance for electric current to reduce the risk of electric shock. This product's power cord has an equipment-earthing conductor and an earthing plug. **IMPORTANT: If the power cord is damaged, it must be replaced with a manufacturer-recommended power cord.**

⚠ DANGER: Improper connection of the equipment-earthing conductor can result in an increased risk of electric shock. Check with a qualified electrician or serviceman if you are in doubt as to whether the product is properly earthed. Do not modify the plug provided with the product—if it will not fit the outlet, have a proper outlet installed by a qualified electrician.

Follow the steps below to plug in the power cord.

1. Plug the indicated end of the power cord (A) into the socket on the incline trainer (B).

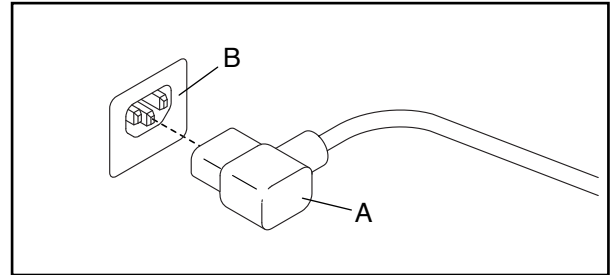

2. Plug the power cord (A) into an appropriate outlet (C) that is properly installed and earthed in accordance with all local codes and ordinances.

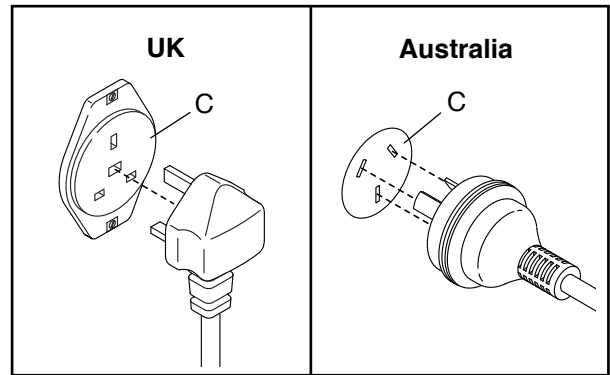

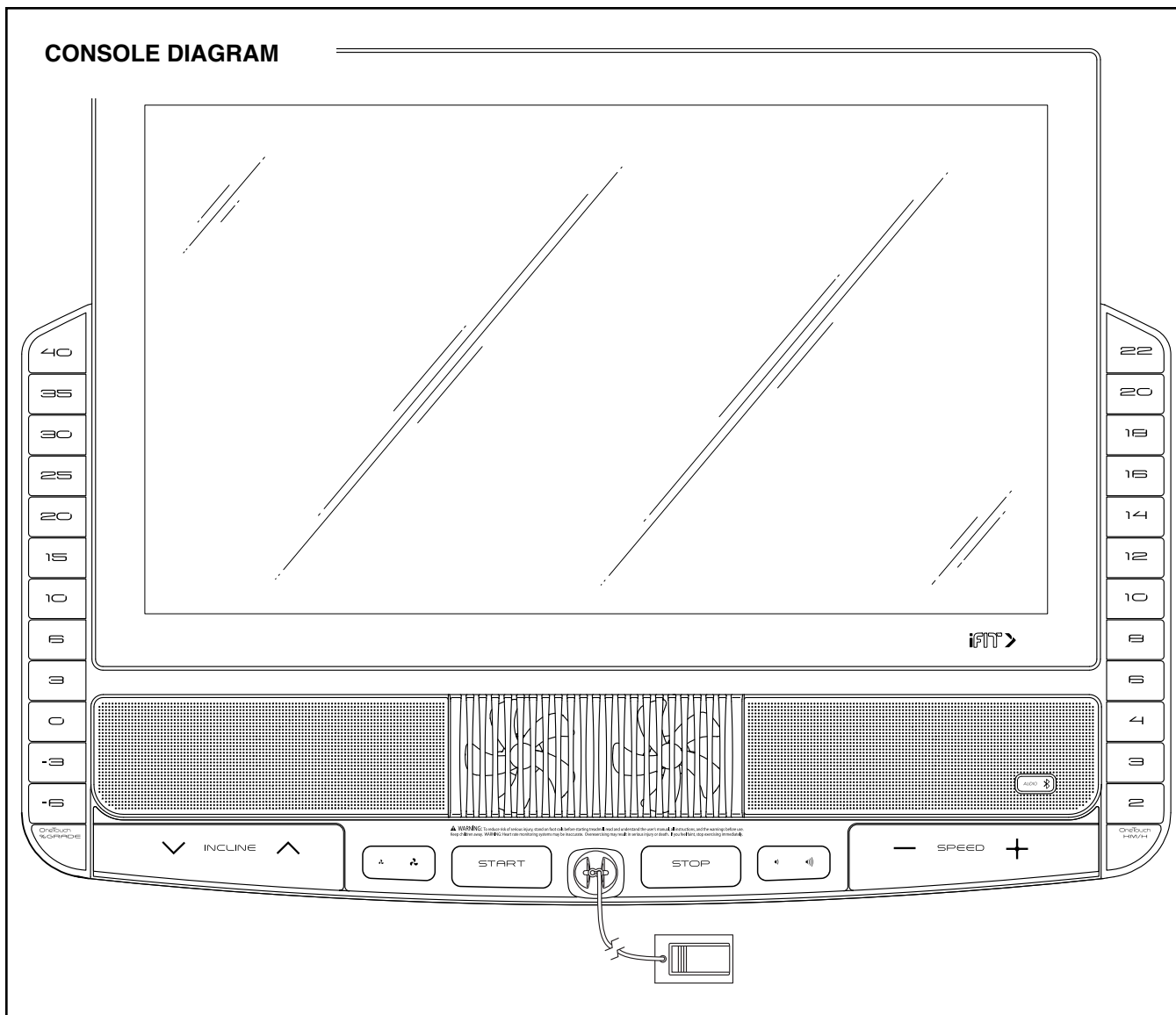

FEATURES OF THE CONSOLE

The advanced incline trainer console offers a selection of features designed to make your workouts more effective and enjoyable.

The console features wireless technology that enables the console to connect to iFit. With iFit, you can access a large and varied workout library. Each workout automatically controls the speed and incline of the incline trainer as it guides you through an effective exercise session. You can also create your own workouts, track your workout results, and access many other features.

When you use the manual mode, you can change the speed and incline of the incline trainer with the touch of a button. As you exercise, the console will display instant exercise feedback.

You can even measure your heart rate when you use a compatible wearable heart rate monitor. **See page 24 to purchase a wearable heart rate monitor.**

You can also listen to your favorite workout music or audio books with the console's sound system while you exercise.

To turn on the power, see page 15. To learn how to use the touch screen, see page 15. To set up the console, see page 16.

HOW TO TURN ON THE POWER

IMPORTANT: If the incline trainer has been exposed to cold temperatures, allow it to warm to room temperature before you turn on the power. If you do not do this, you may damage the console displays or other electrical components.

Plug in the power cord (see page 13). Next, locate the power switch on the incline trainer frame near the power cord. Press the power switch into the reset position (D).

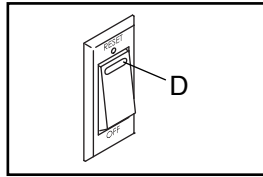

IMPORTANT: Any time that the incline trainer is turned off, wait for a minimum of five minutes before turning it on again. This is necessary to allow any residual electrical charge to dissipate from the incline trainer's electronics.

Next, stand on the foot rails of the incline trainer. Locate the clip (E) attached to the key (F), and slide the clip securely onto the waistband of your clothes. Then, insert the key into the console. **Note: It may take some time**

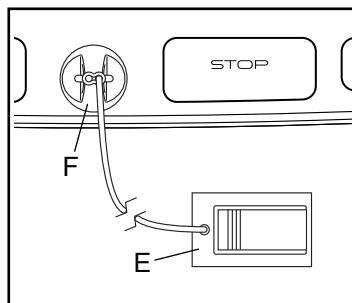

for the console to be ready for use. IMPORTANT: In an emergency, the key can be pulled from the console, causing the walking belt to slow to a stop. Test the clip by carefully taking a few steps backward; if the key is not pulled from the console, adjust the position of the clip.

Note: The console can display speed and distance in either miles or kilometers. To find which unit of measurement is selected, see HOW TO CHANGE CONSOLE SETTINGS on page 21.

HOW TO USE THE TOUCH SCREEN

The console features a tablet with a full-color touch screen. The following information will help you become familiar with the tablet's advanced technology:

- The console functions similarly to other tablets. You can slide or flick your finger against the screen to move certain images on the screen, such as the displays in a workout (see step 5 on page 17). However, you cannot zoom in and out by sliding your fingers on the screen.
- The screen is not pressure sensitive. You do not need to press hard on the screen.
- To type information into a text box, touch the text box to view the keyboard. To use numbers or other characters on the keyboard, touch the ?123 button. To view more characters, touch the ~[< button. Touch the ?123 button again to return to the number keyboard. To return to the letter keyboard, touch the ABC button. To use a capital character, touch the button with an upward-facing arrow. To use multiple capital characters, touch and hold the arrow button. To return to the lowercase keyboard, touch the arrow button again. To clear the last character, touch the button with a backward-facing arrow and an X.

HOW TO SET UP THE CONSOLE

Before using the incline trainer for the first time, set up the console.

1. Connect to your wireless network.

To access the internet, download iFit workouts, and use several other features of the console, you must be connected to a wireless network. Follow the prompts on the screen to connect the console to your wireless network.

2. Customize settings.

Fill in the form on the screen to set the console to display the desired unit of measurement and your time zone. Note: If you need to change these settings later, see HOW TO CHANGE CONSOLE SETTINGS on page 21.

3. Log into or create an iFit account.

Provide your email address, and follow the prompts on the screen to sign up for or log into your iFit account.

4. Check for firmware updates.

First, touch your name or *Hello* on the screen, and then touch *Settings*. Next, select the maintenance section. Then, touch *Update* to check for firmware updates using your wireless network. See step 5 on page 22 for more information.

5. Calibrate the incline system.

First, touch your name or *Hello* on the screen. Next, select the settings main menu. Then, select the maintenance section, touch *Calibrate Incline*, and then touch *Begin* to calibrate the incline system. See step 6 on page 22 for more information.

The console is now ready for you to begin working out. The following pages explain the various workouts and other features that the console offers.

To use the manual mode, see page 17. **To use a map workout**, see page 18. **To use a draw your own map workout**, see page 19. **To use a distance or time workout**, see page 20. **To use the sled push feature**, see page 21.

To view or change console settings, see page 21. **To connect to a wireless network**, see page 23. **To use the sound system**, see page 24.

IMPORTANT: If there are sheets of plastic on the console, remove the plastic. To prevent damage to the walking platform, wear clean athletic shoes while using the incline trainer. The first time you use the incline trainer, observe the alignment of the walking belt, and center the walking belt if necessary (see page 29).

HOW TO USE THE MANUAL MODE

1. Insert the key into the console.

See HOW TO TURN ON THE POWER on page 15.

Note: It may take some time for the console to be ready for use.

2. Select the main menu.

When you turn on the power, the main menu will appear after the console boots up. If you are in a workout or the settings menu, touch the back arrow or the x on the screen to return to the main menu.

Note: If you plan to use a wearable heart rate monitor with the console, you must put on the heart rate monitor **before you start the walking belt**. The console will automatically search for the heart rate monitor for 30 seconds when you start the walking belt at the beginning of each workout. **See page 24 to purchase a wearable heart rate monitor.**

3. Start the walking belt and adjust the speed.

Touch *Manual Start* on the screen or press the Start button on the console to start the walking belt. The walking belt will begin to move at a low speed. As you exercise, change the speed of the walking belt as desired by pressing the speed increase and decrease buttons. Each time you press one of the buttons, the speed setting will change in small increments; if you hold down the button, the speed setting will change more quickly.

If you press one of the numbered speed buttons, the walking belt will gradually change speed until it reaches the selected speed setting.

To stop the walking belt, press the Stop button or tap the middle of the screen. To restart the walking belt, press the Start button.

4. Change the incline of the incline trainer as desired.

To change the incline of the incline trainer, press the incline increase and decrease buttons or one of the numbered incline buttons. Each time you press one of the buttons, the incline will gradually change until it reaches the selected incline setting.

Note: If the walking belt is moving at a high speed and you adjust the incline below 0% or above 15.5%, the speed of the walking belt may automatically decrease.

IMPORTANT: The first time you use the incline trainer, you must calibrate the incline system (see step 6 on page 22).

5. Monitor your progress with the display modes.

While you walk or run on the incline trainer, a selection of workout information will be displayed:

- The incline level of the incline trainer
- The elapsed time
- The approximate number of calories you have burned
- The distance that you have walked or run
- The speed of the walking belt

Additional information is also available. To view or browse additional statistics and charts, swipe down from the top of the screen. You can also touch the + button on the screen to view stats or charts.

Note: To record heart rate information, a compatible heart rate monitor must be in use (see page 24).

If desired, adjust the volume by pressing the volume buttons on the console.

To pause the workout, tap the screen or press the Stop button on the console. To continue the workout, touch the play icon on the screen or press the Start button.

6. Turn on the fan if desired.

The fan features several speed settings. Press the fan buttons repeatedly to select a fan speed or to turn on or turn off the fan.

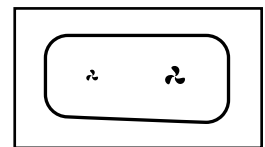

7. When you are finished exercising, remove the key from the console.

Step onto the foot rails and press the Stop button on the console or tap on the screen. Then, touch the stop icon on the screen or press the Stop button again. A workout summary will appear on the screen. If you wish to save your workout for future use, you can add it as a favorite by touching the heart icon on the screen. You may also be able to either save or publish your results using one of the options on the screen. Touch *Finish* to exit to the main menu. Then, remove the key from the console and put it in a secure place.

When you are finished using the incline trainer, press the power switch into the off position and unplug the power cord. **IMPORTANT: If you do not do this, the incline trainer's electrical components may wear prematurely.**

HOW TO USE A MAP WORKOUT

Note: To use a map workout, the console must be connected to a wireless network (see HOW TO CONNECT TO A WIRELESS NETWORK on page 23).

1. Insert the key into the console.

See HOW TO TURN ON THE POWER on page 15.

2. Select the main menu or the workout library.

Touch *Home* or *Browse* on the screen to select either the main menu or the workout library.

3. Select a map workout.

To select a map workout, touch the desired button on the screen. Note: The featured map workouts on your console will change periodically. If you wish to save one of the featured workouts for future use, you can add it as a favorite by touching the heart icon on the screen. To draw your own map workout, see page 19.

The screen will show the duration and distance of the workout, and the approximate number of calories you will burn during the workout.

4. Start the workout.

Touch *Start* to start the workout. A moment after you touch the button, the walking belt will begin to move. Hold the handrails and begin walking.

During the workout, a map on the screen will show your progress.

When you reach the end of the workout, the walking belt will slow to a stop, and a workout summary will appear on the screen. After you view the workout summary, touch *Finish* to return to the main menu. You may also be able to either save or publish your results using one of the options on the screen.

5. Monitor your progress with the display modes.

See step 5 on page 17.

6. Turn on the fan if desired.

See step 6 on page 17.

7. When you are finished exercising, remove the key from the console.

See step 7 at the left.

HOW TO USE A DRAW YOUR OWN MAP WORKOUT

Note: To use a draw your own map workout, the console must be connected to a wireless network (see HOW TO CONNECT TO A WIRELESS NETWORK on page 23).

1. Insert the key into the console.

See HOW TO TURN ON THE POWER on page 15.

2. Select a draw your own map workout.

To select a draw your own map workout, touch Create on the screen.

3. Draw your map.

Navigate to the area on the map where you want to draw your workout by sliding your fingers on the screen. Tap the screen to add the start point for your workout. Then, tap the screen to add the end point for your workout. Note: If you want to start and end the workout at the same point, use the *Loop* or *Out & Back* options. You can also select whether you want your workout to snap to the road.

If you make a mistake, you can touch *Undo*.

The screen will display the elevation and distance stats for your workout. If desired, you can change the default speed.

4. Save your workout.

Touch *Save New Workout* on the screen. If desired, change the title of the workout or add a description, and then press the > symbol on the screen.

5. Start the workout.

Touch *Start* on the screen to start the workout. A moment after you touch the button, the walking belt will begin to move. Hold the handrails and begin walking. See step 4 on page 18 for more information.

6. Monitor your progress with the display modes.

See step 5 on page 17.

7. Turn on the fan if desired.

See step 6 on page 17.

8. When you are finished exercising, remove the key from the console.

See step 7 on page 18.

HOW TO USE A DISTANCE OR TIME WORKOUT

Note: To use a distance or time workout, the console must be connected to a wireless network (see HOW TO CONNECT TO A WIRELESS NETWORK on page 23). An iFit account is also required.

1. Add workouts to your schedule on iFit.com.

On your computer, smartphone, tablet, or other device, open an internet browser, go to iFit.com, and sign in to your iFit account.

Next, navigate to Menu > Library on the website. Browse the workout programs in the library and join the desired workouts.

Then, navigate to Menu > Schedule to view your schedule. All of the workouts that you have joined will appear on your schedule; you can arrange or delete the workouts on your schedule as desired.

Take time to explore the iFit.com website before you log out.

2. Insert the key into the console.

See HOW TO TURN ON THE POWER on page 15.

3. Select the main menu.

See step 2 on page 17.

4. Log in to your iFit account.

If you have not already done so, touch *Login* to log in to your iFit account. The screen will ask for your iFit.com username and password. Enter them and touch Submit. Touch the Cancel button to exit the login screen.

5. Select a distance or time workout that you have previously added to your schedule on iFit.com.

Touch the calendar icon to download a distance or time workout from your schedule.

Note: Before workouts will download, you must add them to your schedule on iFit.com.

When you select a distance or time workout, the screen will show the name, the estimated duration, and the distance of the workout.

6. Start the workout.

See step 4 on page 18. Note: During a distance or time workout, the display will not show a map.

7. Monitor your progress with the display modes.

See step 5 on page 17. The screen will show the elapsed distance or time, and the remaining distance or time.

8. Turn on the fan if desired.

See step 6 on page 17.

9. When you are finished exercising, remove the key from the console.

See step 7 on page 18.

For more information about iFit, go to iFit.com.

HOW TO USE THE SLED PUSH FEATURE

1. Insert the key into the console.

See HOW TO TURN ON THE POWER on page 15.

2. Select the main menu.

See step 2 on page 17.

3. Start the walking belt and adjust the speed to 2 Km/H. Then, adjust the incline to 0%.

See steps 3 and 4 on page 17. **IMPORTANT: Do not use the sled push feature when the incline trainer is off or when the speed setting is higher than 2 Km/H. Do not use the sled push feature when the incline setting is higher or lower than 0%.**

4. See page 5. Grip the push bar or the sled grips with both hands.

5. Use your body to manually move the walking belt at the desired speed.

HOW TO CHANGE CONSOLE SETTINGS

IMPORTANT: Some of the settings and features described may not be enabled. Occasionally, a firmware update may cause your console to function slightly differently.

1. Select the settings main menu.

First, turn on the power and insert the key into the console (see HOW TO TURN ON THE POWER on page 15). Note: It may take a few moments for the console to be ready for use.

Next, select the main menu. When you turn on the console, the main menu will appear on the screen after the console boots up. If you are in a workout, touch the screen, touch *Pause*, touch *End*, and then touch *Finish* to return to the main menu.

Next, touch your name or *Hello* on the screen, and then touch *Settings*. The settings menu will appear on the screen.

2. Navigate the settings menus and change settings as desired.

Slide or flick the screen to scroll upward or downward if necessary. To view a settings menu, simply touch the menu name. To exit a menu, touch the back button (arrow symbol). You may be able to view and change settings in the following settings menus:

Account

- My Profile
- In Workout
- Manage Accounts

Equipment

- Equipment Info
- Equipment Settings
- Maintenance
- Wi-Fi

About

- Legal

3. Customize the unit of measurement and other settings.

To customize the unit of measurement, the time zone, or other settings, touch *Equipment Settings*, and then touch the desired settings.

The console can display speed and distance in standard or metric units of measurement.

4. View machine information.

Touch *Equipment Info*, and then touch *Machine Info* to view information about your incline trainer.

5. Update the console firmware.

For the best results, regularly check for firmware updates. Touch *Maintenance*, and then touch *Update* to check for firmware updates using your wireless network. The update will begin automatically. **IMPORTANT: To avoid damaging the console, do not turn off or unplug the incline trainer while the firmware is being updated.**

The screen will show the progress of the update. When the update is complete, the incline trainer will turn off and then turn back on. If it does not, use the power switch (see HOW TO TURN ON THE POWER on page 15) to turn the incline trainer off, wait for a few seconds, and then turn it back on again. Note: It may take a few minutes for the console to be ready for use.

Note: Occasionally, a firmware update may cause the console to function slightly differently. These updates are always designed to improve your exercise experience.

6. Calibrate the incline system of the incline trainer.

Touch *Calibrate Incline*, and then touch *Begin* to calibrate the incline system. The incline trainer will automatically rise to the maximum incline level, and then return to the starting position. This will calibrate the incline system. Touch *Cancel* to return to the maintenance section. When the incline system is calibrated, touch *Finish*.

IMPORTANT: Keep pets, feet, and other objects away from the incline trainer while the incline system is calibrating. In an emergency, pull the key from the console to stop the incline calibration.

7. Exit the settings main menu.

If you are in a settings menu, touch the back arrow. Then, touch the close button (x symbol) to exit the settings main menu.

HOW TO CONNECT TO A WIRELESS NETWORK

The console is Wi-Fi enabled, allowing you to set up a wireless network connection.

1. Select the main menu.

See step 2 on page 17.

2. Select the wireless network mode.

Touch your name in the upper-left corner, then touch the Wi-Fi® symbol to enter the wireless network mode.

3. Enable Wi-Fi.

Make sure that Wi-Fi is enabled. If it is not, touch the Wi-Fi toggle to enable a wireless connection.

4. Set up and manage a wireless network connection.

When Wi-Fi is enabled, the screen will show a list of available networks. Note: It may take several seconds for the list of wireless networks to appear.

Note: You must have your own wireless network and an 802.11b/g/n router with SSID broadcast enabled (hidden networks are not supported).

When a list of networks appears, touch the desired network. Note: You will need to know your network name (SSID). If your network has a password, you will also need to know the password.

An information box will ask if you want to connect to the wireless network. Touch the Connect button to connect to the network or touch the Cancel button to return to the list of networks. If the network has a password, touch the password entry box. A keyboard will appear on the screen. To view the password as you type it, touch the Show Password checkbox.

To use the keyboard, see HOW TO USE THE TOUCH SCREEN on page 15.

When the console is connected to your wireless network, a checkmark will appear next to the wireless network name. Then, touch the back button on the screen to return to the wireless network mode.

To disconnect from a wireless network, touch and hold the name of the wireless network and then touch the Forget Network button.

If you are having problems connecting to an encrypted network, make sure that your password is correct. Note: Passwords are case-sensitive.

Note: The console supports unsecured and secured (WEP, WPA™, and WPA2™) encryption. A broadband connection is recommended; performance depends on connection speed.

Note: If you have questions after following these instructions, go to support.iFit.com for assistance.

5. Exit the wireless network menu.

To exit the wireless network menu, touch the back button on the screen.

HOW TO USE THE SOUND SYSTEM

To play music or audio books through the console sound system while you exercise, you can connect a personal audio device to the console with an audio cable, or you can connect wirelessly if your device is Bluetooth-enabled.

You can then adjust the volume level using the volume buttons on the console or the volume control on your personal audio device.

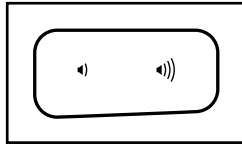

To use an audio cable

Plug a 3.5 mm male to 3.5 mm male audio cable (not included) into the jack on the console and into a jack on your personal audio device; make sure that the audio cable is fully plugged in. Note: To purchase an audio cable, see your local electronics store.

To use Bluetooth

1. **Make sure that your device's Bluetooth setting is turned on, and place or hold your device near the console.**
2. **Press and hold the Bluetooth Audio button on the console's speaker grill for 3 seconds.**

A tone will sound and the Bluetooth button will begin flashing to indicate that the console has entered pairing mode.

3. **Pair your device to the console.**

Once your device and the console pair successfully, the audio from your device will play through the console's speakers.

Note: The console can save eight devices in its memory. If you have previously paired your device to the console, you can simply press the Bluetooth Audio button to connect your device to the console.

4. **Erase the console's device memory if necessary.**

If you need to erase all the Bluetooth-enabled devices saved in the console's memory, press and hold the Bluetooth Audio button for 10 seconds.

THE OPTIONAL HEART RATE MONITOR

Whether your goal is to burn fat or to strengthen your cardiovascular system, the key to achieving the best results is to maintain the proper heart rate during your workouts.

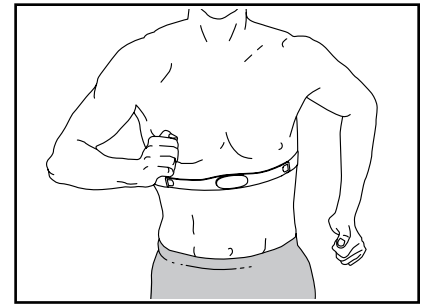

A wearable rate monitor will enable you to continuously monitor your heart rate while you exercise, helping you to reach your personal fitness goals. **To purchase a wearable heart rate monitor, please see the front cover of this manual.**

Note: The console is compatible with all Bluetooth Smart heart rate monitors.

To connect a wearable heart rate monitor to the console, first put it on as directed in its included instructions. Then, when you begin a workout or start the walking belt in manual mode, the console will search for the wearable heart rate monitor for 30 seconds and connect automatically.

HOW TO MOVE THE INCLINE TRAINER

Before moving the incline trainer, insert the key into the console (A), raise the incline to the maximum incline level, remove the key, and unplug the power cord.

Due to the size and weight of the incline trainer, moving it requires two or three persons. Hold the uprights (B) firmly near the console (A). Tip the incline trainer back until it rolls freely on the wheels (C).

CAUTION: To decrease the possibility of injury or of damage to the incline trainer, do not lift the incline trainer by the plastic belly pan (D). Do not pull on the console.

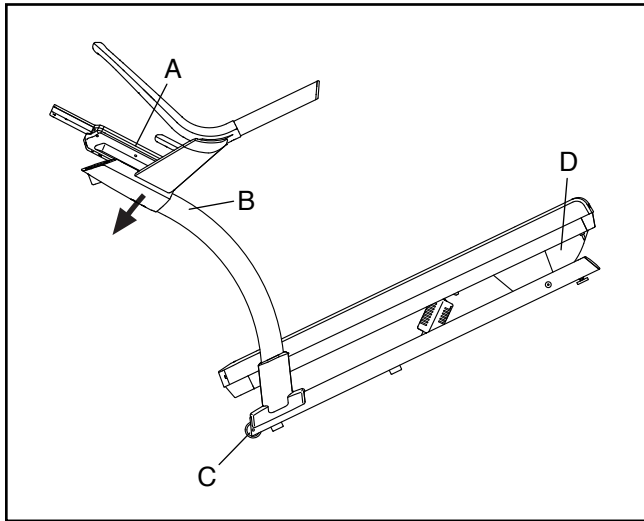

Carefully roll the incline trainer on the wheels to the desired location, and then lower it to the level position. **CAUTION:** To reduce the risk of injury, use extreme caution while moving the incline trainer. Do not attempt to move the incline trainer over uneven surfaces.

Make sure that the incline trainer rests firmly on the floor. If the incline trainer rocks even slightly, turn the Leveling Feet (77) as needed until the rocking motion is eliminated.

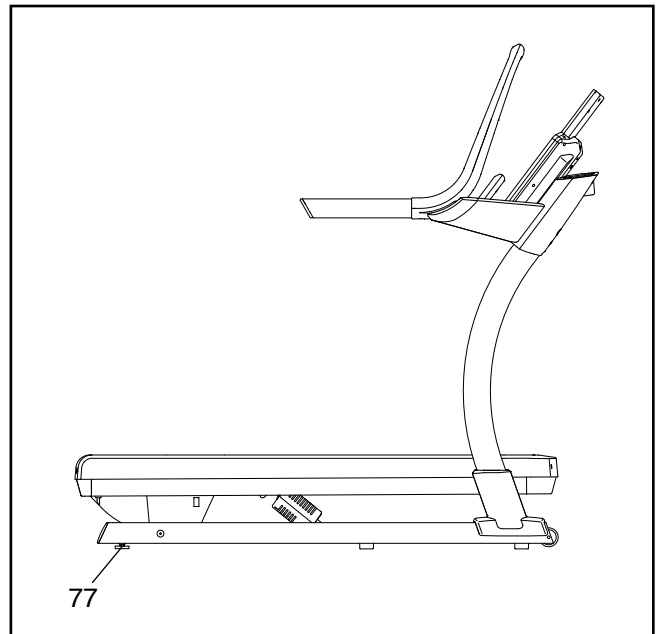

MAINTENANCE AND TROUBLESHOOTING

MAINTENANCE

Regular maintenance is important for optimal performance and to reduce wear. Inspect and properly tighten all parts each time the incline trainer is used. Replace any worn parts immediately. Use only manufacturer-supplied parts.

Regularly clean the incline trainer and keep the walking belt clean and dry. First, **press the power switch into the off position and unplug the power cord**. Wipe exterior parts of the incline trainer with a damp cloth and a small amount of mild soap. **IMPORTANT: Do not spray liquids directly onto the incline trainer. To avoid damage to the console, keep liquids away from the console.** Then, thoroughly dry the incline trainer with a soft towel.

TROUBLESHOOTING

Most incline trainer problems can be solved by following the simple steps below. Find the symptom that applies, and follow the steps listed. If further assistance is needed, see the front cover of this manual.

SYMPTOM: The power does not turn on

- If an extension cord is needed, use only a 3-conductor, 14-gauge (2 mm²) cord that is no longer than 5 ft. (1.5 m).
- After the power cord has been plugged in, make sure that the key is inserted into the console.
- Check the power switch located on the incline trainer frame near the power cord. If the switch protrudes as shown (A), the switch has tripped. To reset the power switch, wait for five minutes and then press the switch back in (B).

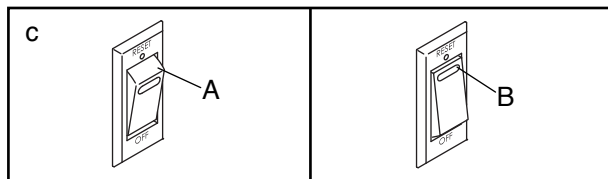

SYMPTOM: The power turns off during use

- Check the power switch (see drawing c at the left). If the switch has tripped, wait for five minutes and then press the switch back in.
- Make sure that the power cord is plugged in. If the power cord is plugged in, unplug it, wait for five minutes, and then plug it back in.
- Remove the key from the console, and then reinsert it.
- If the incline trainer still will not run, please see the front cover of this manual.

SYMPTOM: The incline of the incline trainer does not change correctly

- Calibrate the incline system (see step 6 on page 22).

SYMPTOM: The walking belt does not run

If the console does not function properly, see page 27. If the console displays time and distance while a workout is running, but the walking belt does not run, do the following:

- Turn off the power (see page 15) and unplug the power cord.
- Wait for a minimum of five minutes to make sure that any residual charge has dissipated from the incline trainer's electronics.
- Plug in the power cord (see page 13), turn on the power, and start the walking belt again.
- If the walking belt still does not run, please see the front cover of this manual.

SYMPTOM: The displays of the console do not function properly

- a. If the console does not display speed or distance properly, remove the key from the console and **UNPLUG THE POWER CORD**. Next, remove the indicated #8 x 3/4" Screw (5), and lift off the Left Foot Rail Cover (44).

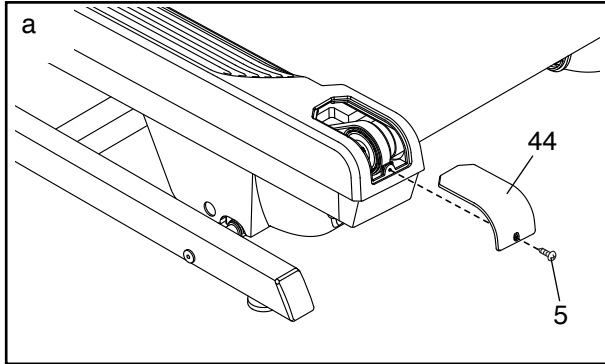

Next, locate the Reed Switch (115) and the Magnet (120) on the left side of the Pulley (42). Turn the Pulley until the Magnet is aligned with the Reed Switch. **The gap between the Magnet and the Reed Switch must be about 1/8 in. (3 mm).** If necessary, loosen the #8 x 3/4" Screw (5), move the Reed Switch slightly, and then retighten the Screw. Then, reattach the Left Foot Rail Cover (see the drawing above), and run the incline trainer for a few minutes to check for a correct speed reading.

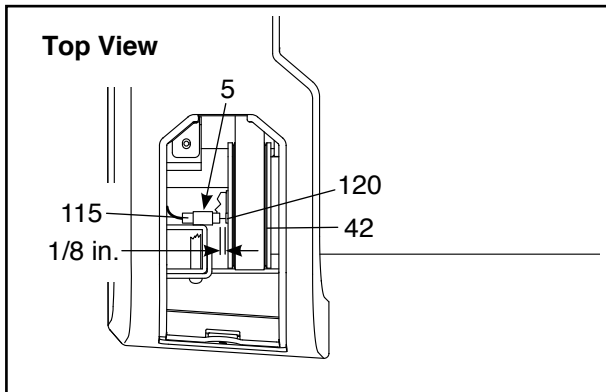

- b. If the console does not boot up properly, or if the console freezes and does not respond, reset the console to the factory default settings.

IMPORTANT: Doing this will erase all the custom settings you have made to the console.

Resetting the console requires two people. First, press the power switch into the off position. Next, locate the small reset opening (C) on the side of the console. Using a bent paper clip (D), press and hold the reset button inside the opening, and have a second person press the power switch into the on (reset) position. Continue holding the reset button (C) until the console turns on. When the reset operation is complete, the console will turn off and then turn back on. If it does not, use the power switch to turn the incline trainer off and then on again. Once the console turns on, check for firmware updates (see step 5 on page 22). Note: It may take a few minutes for the console to be ready for use.

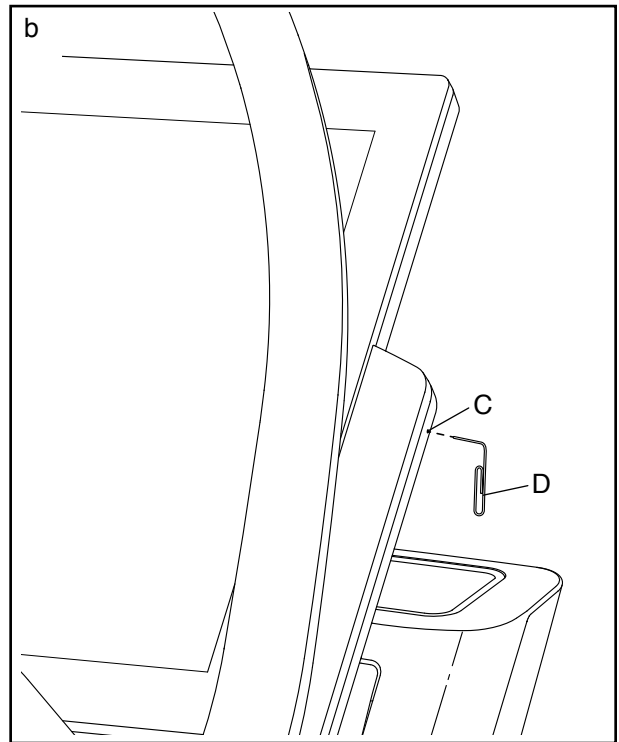

SYMPTOM: The incline trainer will not connect to the wireless network

- a. Make sure that the wireless settings on the console are correct (see page 23).
- b. Make sure that the settings for your wireless network are correct.
- c. If you still have questions, go to support.iFit.com.

SYMPTOM: The console does not stay in place

- a. If the console will not stay in the desired position because it is too loose, turn a hex key in quarter turn increments in the two indicated locations (E) until the console is tightened.

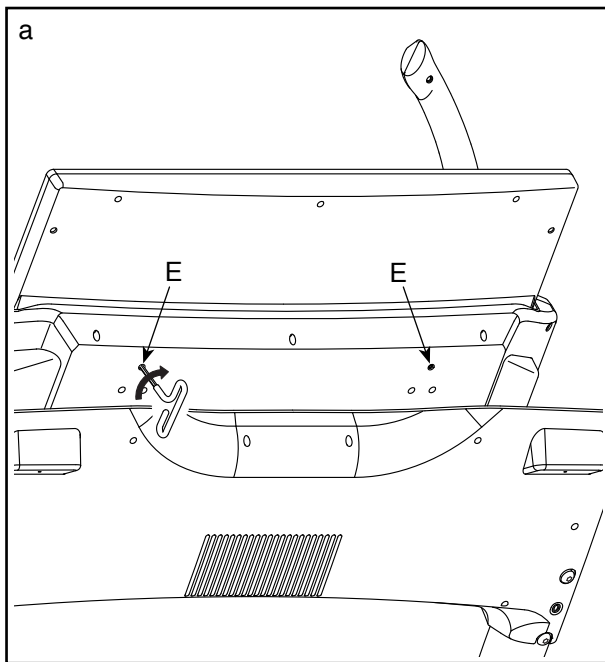

SYMPTOM: The walking belt slows when walked on

- a. If an extension cord is needed, use only a 3-conductor, 14-gauge (2 mm²) cord that is no longer than 5 ft. (1.5 m).
- b. If the walking belt is overtightened, incline trainer performance may decrease and the walking belt may become damaged. First, remove the key and **UNPLUG THE POWER CORD**. Using the hex key, turn both idler roller screws (F) counterclockwise, 1/4 of a turn. When the walking belt is properly tightened, you should be able to lift each edge of the walking belt 3 to 4 in. (8 to 10 cm) off the walking platform. Be careful to keep the walking belt centered. Then, plug in the power cord, insert the key, and walk on the incline trainer for a few minutes. Repeat until the walking belt is properly tightened.

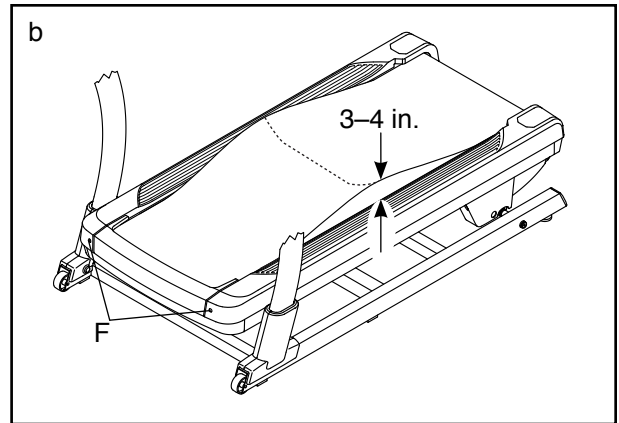

- c. The incline trainer features a walking belt coated with high-performance lubricant. **IMPORTANT: Never apply silicone spray or other substances to the walking belt or the walking platform unless instructed to do so by an authorized service representative. Such substances may deteriorate the walking belt and cause excessive wear.** If you suspect that the walking belt needs more lubricant, see the front cover of this manual.
- d. If the walking belt still slows when walked on, see the front cover of this manual.

SYMPTOM: The walking belt is not centered between the foot rails

- a. **IMPORTANT: If the walking belt rubs against the foot rails (G), the walking belt may become damaged.** First, remove the key and **UNPLUG THE POWER CORD**. If the walking belt has shifted to the left, use the hex key to turn the left idler roller screw clockwise 1/2 of a turn; if the walking belt has shifted to the right, turn the left idler roller screw counterclockwise 1/2 of a turn. Be careful not to overtighten the walking belt. Then, plug in the power cord, insert the key, and walk on the incline trainer for a few minutes. Repeat until the walking belt is centered.

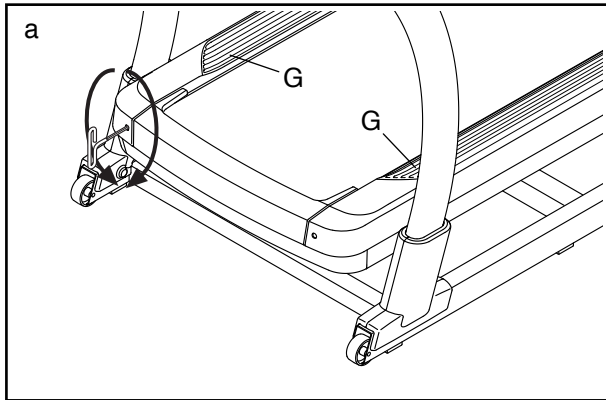

SYMPTOM: The walking belt slips when walked on

- a. First, remove the key and **UNPLUG THE POWER CORD**. Using the hex key, turn both idler roller screws clockwise, 1/4 of a turn. When the walking belt is correctly tightened, you should be able to lift each edge of the walking belt 3 to 4 in. (8 to 10 cm) off the walking platform. Be careful to keep the walking belt centered. Then, plug in the power cord, insert the key, and walk on the incline trainer for a few minutes. Repeat until the walking belt is properly tightened.

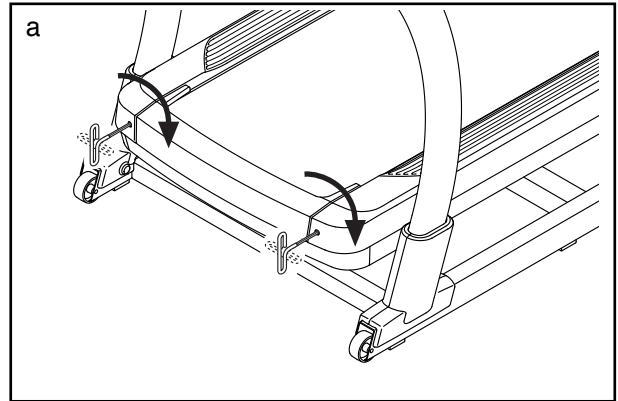

EXERCISE GUIDELINES

⚠️ WARNING: Before beginning this or any exercise program, consult your physician. This is especially important for persons over age 35 or persons with pre-existing health problems.

These guidelines will help you to plan your exercise program. For detailed exercise information, obtain a reputable book or consult your physician. Remember, proper nutrition and adequate rest are essential for successful results.

EXERCISE INTENSITY

Whether your goal is to burn fat or to strengthen your cardiovascular system, exercising at the proper intensity is the key to achieving results. You can use your heart rate as a guide to find the proper intensity level. The chart below shows recommended heart rates for fat burning and aerobic exercise.

165	155	145	140	130	125	115	♥️
145	138	130	125	118	110	103	♥️
125	120	115	110	105	95	90	♥️
<hr/>							
20	30	40	50	60	70	80	

To find the proper intensity level, find your age at the bottom of the chart (ages are rounded off to the nearest ten years). The three numbers listed above your age define your “training zone.” The lowest number is the heart rate for fat burning, the middle number is the heart rate for maximum fat burning, and the highest number is the heart rate for aerobic exercise.

Burning Fat—To burn fat effectively, you must exercise at a low intensity level for a sustained period of time. During the first few minutes of exercise, your body uses carbohydrate calories for energy. Only after the first few minutes of exercise does your body begin to use stored fat calories for energy. If your goal is to burn fat, adjust the intensity of your exercise until your heart rate is near the lowest number in your training zone. For maximum fat burning, exercise with your heart rate near the middle number in your training zone.

Aerobic Exercise—If your goal is to strengthen your cardiovascular system, you must perform aerobic exercise, which is activity that requires large amounts of oxygen for prolonged periods of time. For aerobic exercise, adjust the intensity of your exercise until your heart rate is near the highest number in your training zone.

HOW TO MEASURE YOUR HEART RATE

To measure your heart rate, exercise for at least four minutes. Then, stop exercising and place two fingers on your wrist as shown. Take a six-second heartbeat count, and multiply the result by 10 to find your heart rate. For example, if your six-second heartbeat count is 14, your heart rate is 140 beats per minute.

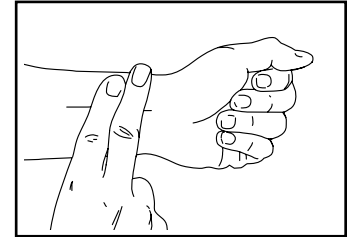

WORKOUT GUIDELINES

Warming Up—Start with 5 to 10 minutes of stretching and light exercise. A warm-up increases your body temperature, heart rate, and circulation in preparation for exercise.

Training Zone Exercise—Exercise for 20 to 30 minutes with your heart rate in your training zone. (During the first few weeks of your exercise program, do not keep your heart rate in your training zone for longer than 20 minutes.) Breathe regularly and deeply as you exercise; never hold your breath.

Cooling Down—Finish with 5 to 10 minutes of stretching. Stretching increases the flexibility of your muscles and helps to prevent post-exercise problems.

EXERCISE FREQUENCY

To maintain or improve your condition, complete three workouts each week, with at least one day of rest between workouts. After a few months of regular exercise, you may complete up to five workouts each week, if desired. Remember, the key to success is to make exercise a regular and enjoyable part of your everyday life.

SUGGESTED STRETCHES

The correct form for several basic stretches is shown at the right. Move slowly as you stretch—never bounce.

1. Toe Touch Stretch

Stand with your knees bent slightly and slowly bend forward from your hips. Allow your back and shoulders to relax as you reach down toward your toes as far as possible. Hold for 15 counts, then relax. Repeat 3 times. Stretches: Hamstrings, back of knees and back.

2. Hamstring Stretch

Sit with one leg extended. Bring the sole of the opposite foot toward you and rest it against the inner thigh of your extended leg. Reach toward your toes as far as possible. Hold for 15 counts, then relax. Repeat 3 times for each leg. Stretches: Hamstrings, lower back and groin.

3. Calf/Achilles Stretch

With one leg in front of the other, reach forward and place your hands against a wall. Keep your back leg straight and your back foot flat on the floor. Bend your front leg, lean forward and move your hips toward the wall. Hold for 15 counts, then relax. Repeat 3 times for each leg. To cause further stretching of the achilles tendons, bend your back leg as well. Stretches: Calves, achilles tendons and ankles.

4. Quadriceps Stretch

With one hand against a wall for balance, reach back and grasp one foot with your other hand. Bring your heel as close to your buttocks as possible. Hold for 15 counts, then relax. Repeat 3 times for each leg. Stretches: Quadriceps and hip muscles.

5. Inner Thigh Stretch

Sit with the soles of your feet together and your knees outward. Pull your feet toward your groin area as far as possible. Hold for 15 counts, then relax. Repeat 3 times. Stretches: Quadriceps and hip muscles.

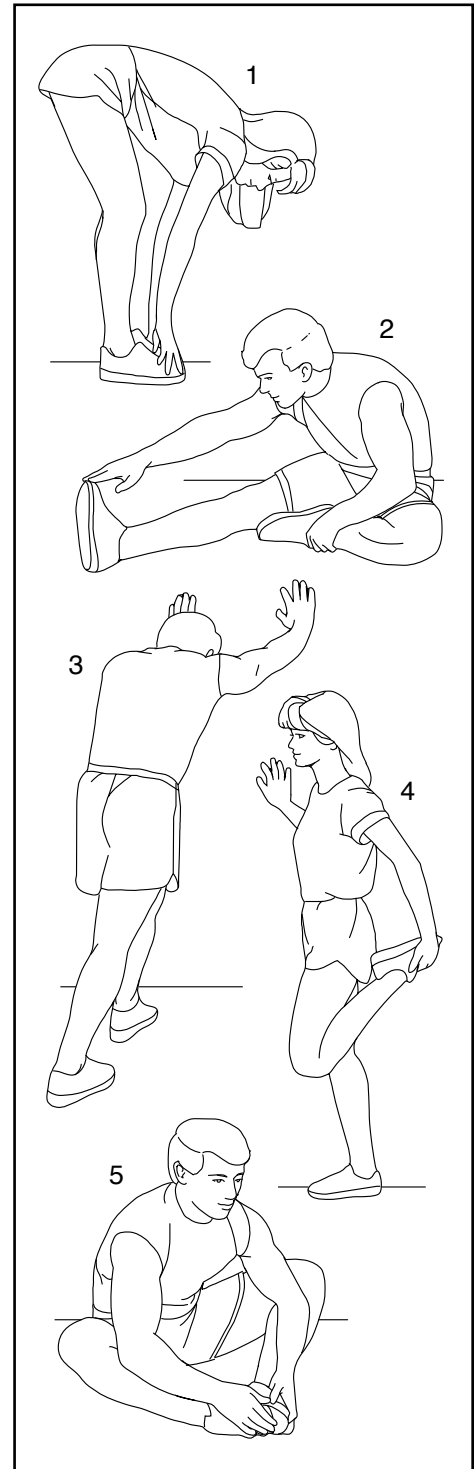

NOTES

PART LIST

Model No. NTL39221-INT.0 R0421A

Key No.	Qty.	Description	Key No.	Qty.	Description
1	4	3/8" x 5 1/2" Screw	51	4	Cushion
2	2	#8 x 1/2" Pan Head Tek Screw	52	1	Base Wire
3	16	3/8" Star Washer	53	4	Rubber Cushion
4	4	#8 x 3/4" Pan Head Tek Screw	54	2	Large Pivot Bushing
5	70	#8 x 3/4" Screw	55	1	Electronics Cover
6	4	#8 Belt Guide Screw	56	1	Incline Motor Top Cover
7	10	#8 x 1/2" Screw	57	4	M3 x 12mm Screw
8	4	1/4" Star Washer	58	1	Incline Motor Bottom Cover
9	8	#8 x 3/4" Washer Head Screw	59	4	Incline Motor Bushing
10	8	#8 x 5/8" Screw	60	1	Incline Motor
11	4	5/16" x 1 1/2" Screw	61	1	Electronics Bracket
12	2	1/4" x 1/2" Screw	62	1	Controller
13	4	1/4" x 2 1/2" Screw	63	1	Resistor
14	1	M8 x 32mm Bolt	64	1	Drive Motor
15	1	M8 x 51mm Bolt	65	4	Standoff
16	12	Hood Clip	66	1	Frame
17	10	#8 x 1/2" Washer Head Screw	67	4	Fan Screw
18	4	3/8" x 3 1/4" Screw	68	1	Left Outside Upright Cover
19	2	M8 Nut	69	1	Left Inside Upright Cover
20	2	5/16" Motor Bolt	70	1	Right Inside Upright Cover
21	2	3/8" x 2 3/8" Screw	71	1	Right Outside Upright Cover
22	4	3/8" x 2 3/4" Screw	72	2	Wheel
23	3	#8 Star Washer	73	4	Base Pad
24	1	Console Back	74	1	Base
25	4	5/16" Flat Washer	75	1	Upright Wire
26	2	3/8" Nut	76	3	Round Grommet
27	4	5/16" Nut	77	2	Leveling Foot
28	1	1/4" Nut	78	2	Axle
29	2	Belt Guide	79	2	Base Cap
30	1	Walking Platform	80	1	Warning Decal
31	1	Walking Belt	81	2	Caution Decal
32	1	Left Foot Rail	82	1	Left Handrail
33	1	Right Foot Rail	83	1	Upright
34	1	Idler Roller	84	2	Console Ground Wire
35	1	Belly Pan Cover	85	1	Power Supply
36	1	Belly Pan	86	2	Handrail Cap
37	1	Power Switch	87	1	Incline Motor Controller
38	2	Belly Pan Grommet	88	1	Key
39	1	Receptacle	89	1	Right Handrail Top
40	1	Power Cord	90	1	Left Handrail Top
41	8	Tie	91	1	Left Tray
42	1	Drive Roller/Pulley	92	1	Console Base
43	1	Right Foot Rail Cover	93	1	Console
44	1	Left Foot Rail Cover	94	1	Right Tray
45	4	Small Pivot Bushing	95	2	#8 x 1" Screw
46	1	Drive Belt	96	2	#8 x 3/4" HiLo Screw
47	1	Front Hood	97	1	Right Handrail
48	1	Front Belly Pan	98	1	Left Handrail Bottom
49	8	Cushion Cap	99	1	Right Handrail Bottom
50	4	Spring	100	2	3/8" x 2 1/4" Screw

Key No.	Qty.	Description	Key No.	Qty.	Description
101	2	Fan	112	1	Left Inside Handrail Cover
102	8	5/16" x 3/4" Screw	113	1	Right Outside Handrail Cover
103	8	5/16" Star Washer	114	1	Right Inside Handrail Cover
104	2	#8 x 2" Screw	115	1	Reed Switch
105	6	#8 x 1 1/4" Screw	116	1	Reed Switch Clip
106	6	#8 x 5/8" Machine Screw	117	2	Motor Bushing
107	2	3/8" x 1/2" Screw	118	1	Motor Isolator
108	4	5/16" x 3/4" Patch Screw	119	1	Filter
109	1	Push Bar Bottom	120	1	Magnet
110	1	Push Bar Top	*	-	User's Manual
111	1	Left Outside Handrail Cover			

Note: Specifications are subject to change without notice. For information about ordering replacement parts, see the back cover of this manual. *These parts are not illustrated.

EXPLODED DRAWING A

Model No. NTL39221-INT.0 R0421A

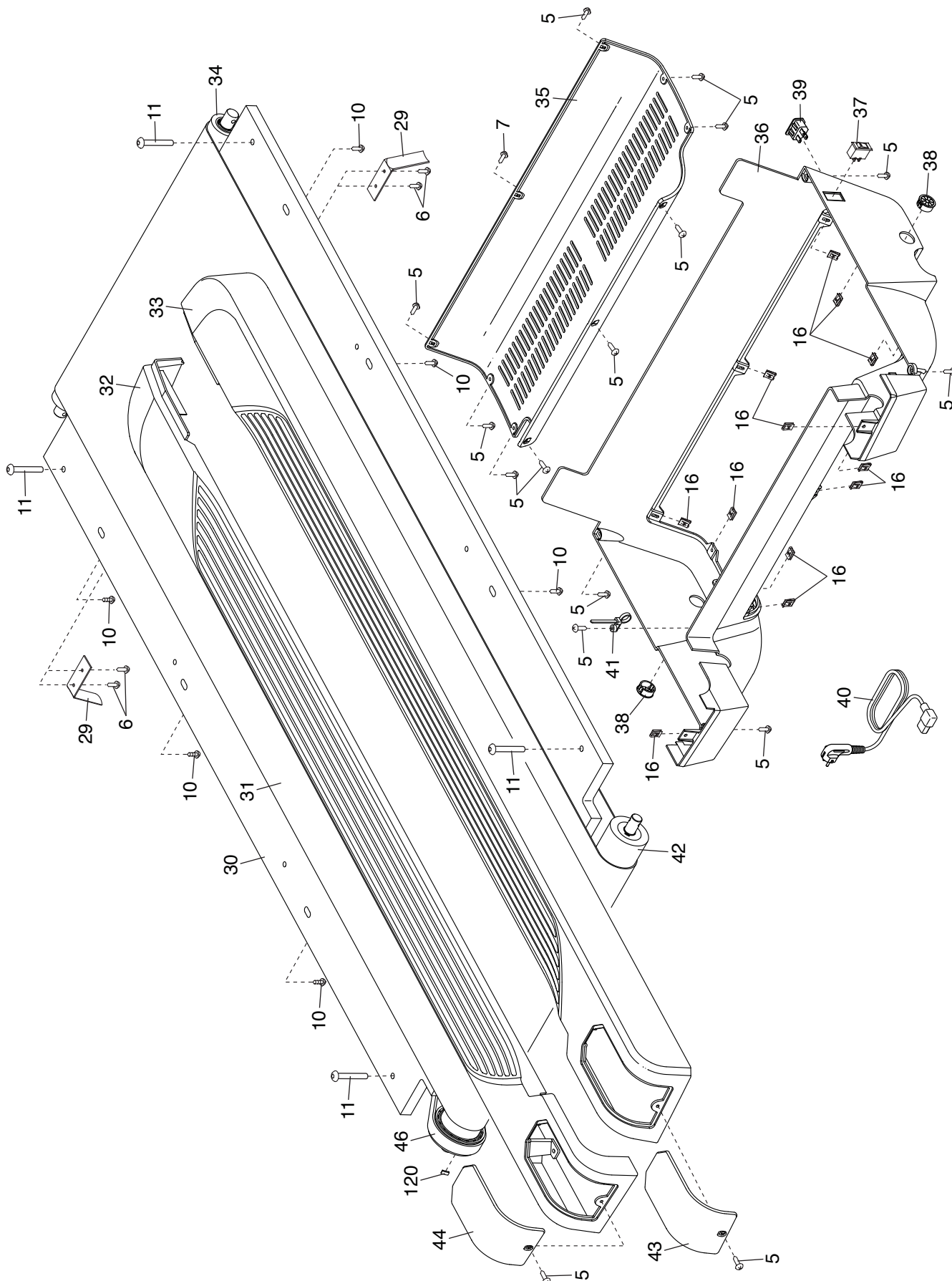

EXPLODED DRAWING B

Model No. NTL39221-INT.0 R0421A

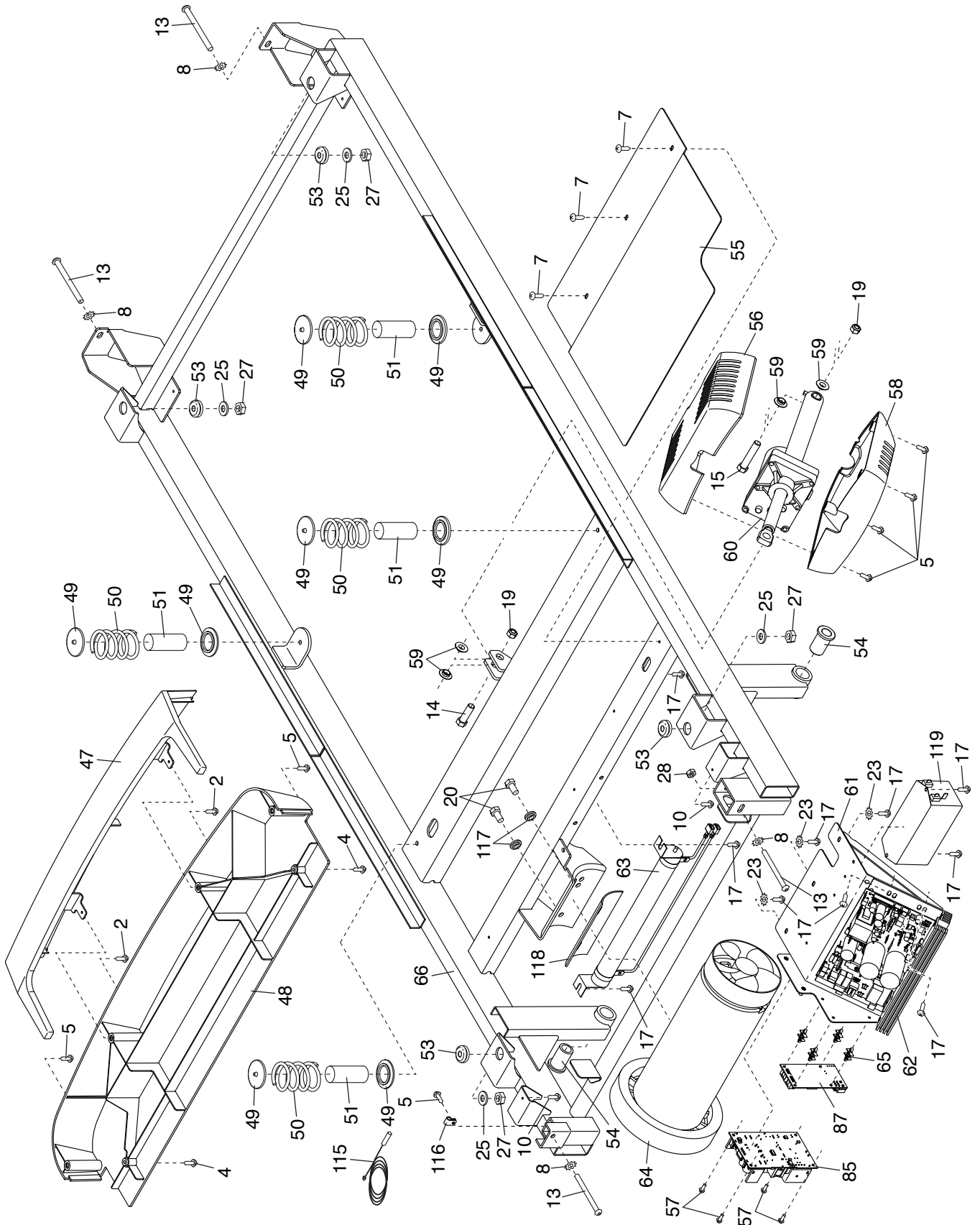

EXPLODED DRAWING C

Model No. NTL39221-INT.0 R0421A

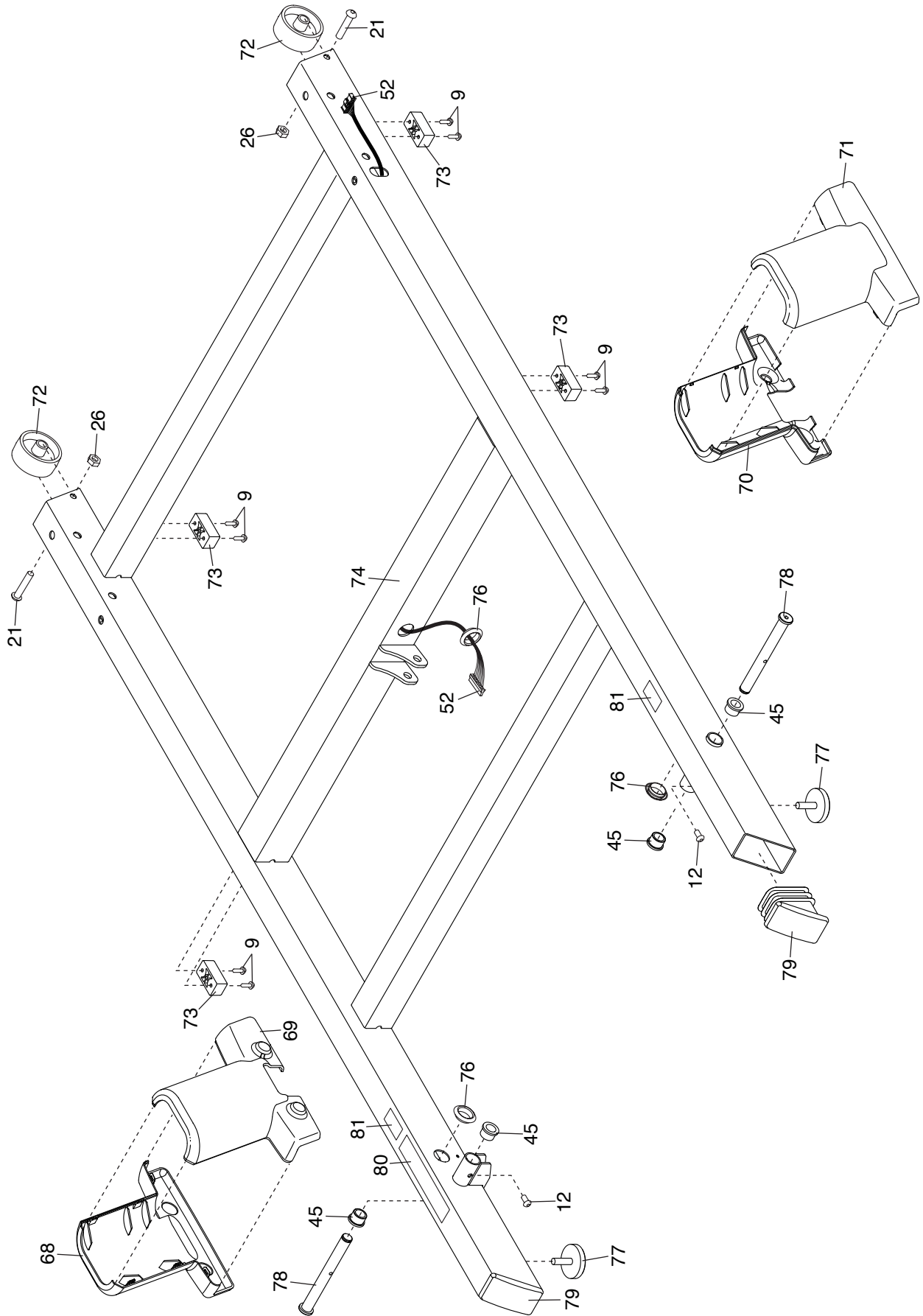

EXPLODED DRAWING D

Model No. NTL39221-INT.0 R0421A

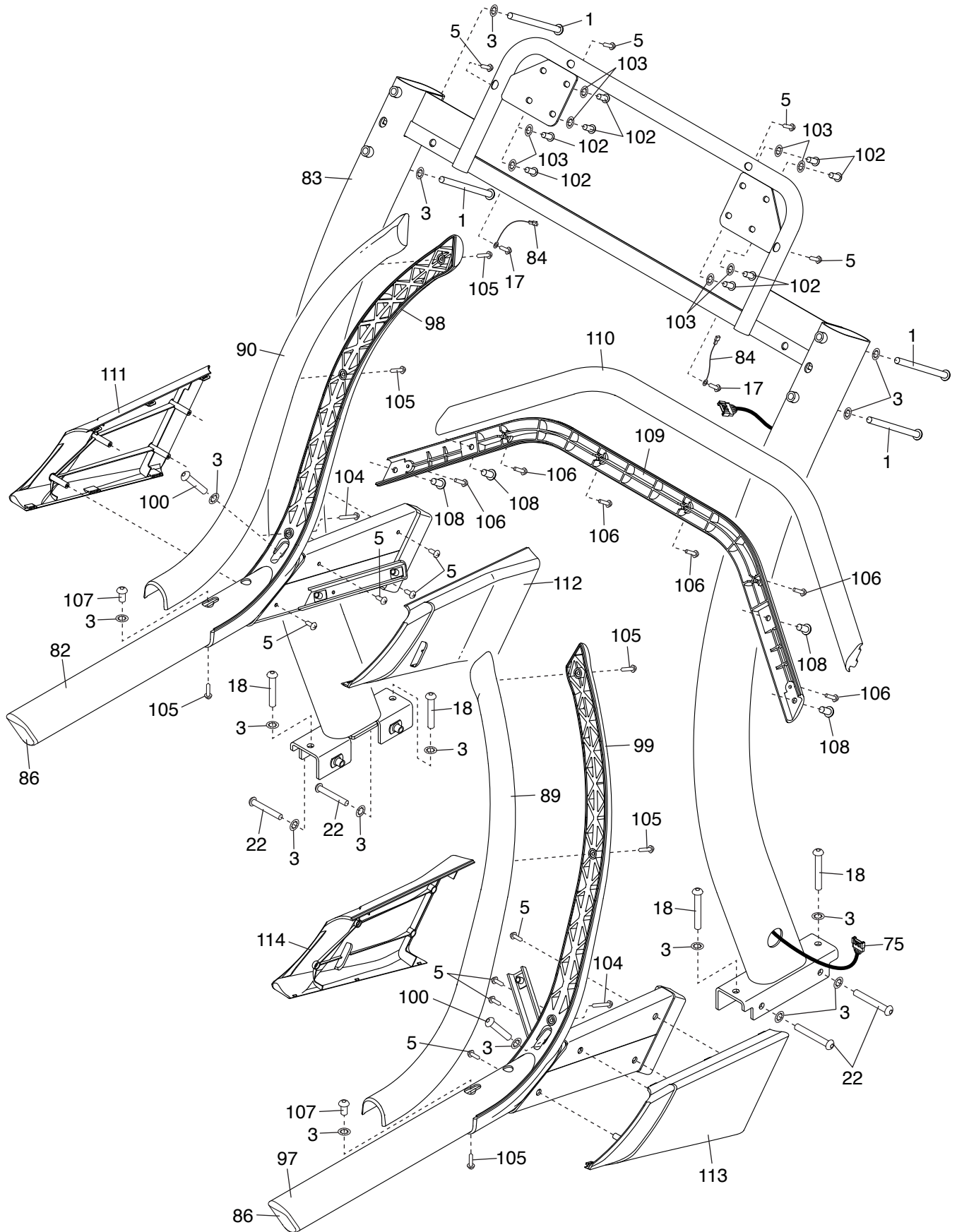

EXPLODED DRAWING E

Model No. NTL39221-INT.0 R0421A

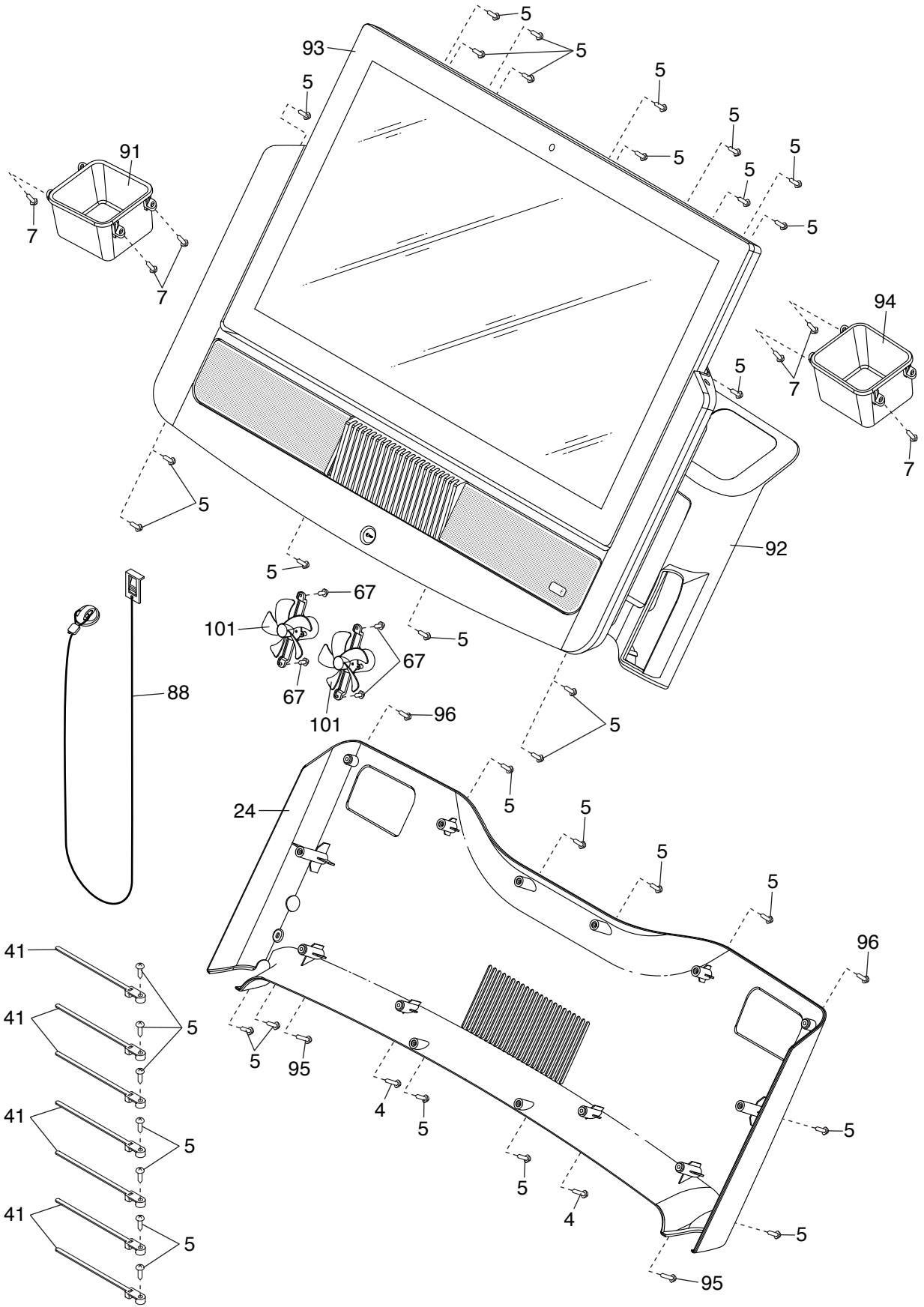

ORDERING REPLACEMENT PARTS

To order replacement parts, please see the front cover of this manual. To help us assist you, be prepared to provide the following information when contacting us:

- the model number and serial number of the product (see the front cover of this manual)
- the name of the product (see the front cover of this manual)
- the key number and description of the replacement part(s) (see the PART LIST and the EXPLODED DRAWING near the end of this manual)

RECYCLING INFORMATION

This electronic product must not be disposed of in municipal waste. To preserve the environment, this product must be recycled after its useful life as required by law.

Please use recycling facilities that are authorized to collect this type of waste in your area. In doing so, you will help to conserve natural resources and improve European standards of environmental protection. If you require more information about safe and correct disposal methods, please contact your local city office or the establishment where you purchased this product.

